

Appendix 4.8  
Generation Adequacy  
Evaluation  
(Karki, 2017)

---

**Generation Adequacy Evaluation of the  
Yukon Energy Corporation Power System  
Incorporating Major Power Delivery Constraints**

**Prepared By**

**Rajesh Karki, Ph.D., P.Eng.**

**February 23, 2017**

## **EXECUTIVE SUMMARY**

This report presents adequacy evaluation studies of the Yukon Energy Corporation (YEC) electric power system considering major capacity delivery constraints. The results of the studies carried out to develop a suitable reliability model for the existing YEC system are presented. The developed model was integrated in a software tool named YESREL which is a modified version of WAFSREL [1]. A number of case studies were also conducted using the YESREL program.

The Whitehorse, Aishihik and Faro (WAF) sub-systems were the major components of the YEC system in 2005, when a study [2] was carried out to recommend a reliability criterion of LOLE = 2 hours/year for capacity planning. The 2005 study showed that the capacity constraint imposed by the line L171, that interconnects the Aishihik hydro plant, had significant impact on the overall adequacy of the WAF system, and was therefore incorporated in the reliability model. A reliability software WAFSREL [1] then developed included this model in reliability evaluation of the WAF system. Another reliability study [3] was carried out in 2011 after the Mayo and Dawson (MD) sub-systems were integrated to the WAF system. The study recommended that the WAFREL software that was developed for the WAF system should be upgraded in response to the system changes in the WAF-MD system.

This report consists of 5 sections. Section 1 provides introduction to the work in this project. Section 2 presents the generation and load data of the WAF-MD system. The total system capacity of 131.21 MW was considered for the WAF-MD system. The total effective winter capacity was reduced to 109.61 MW as the Whitehorse and Mayo hydro plants during the winter season are limited to 24.5 MW and 9.0 MW respectively due to seasonal hydrological constraints. Generating unit forced outage rate of 1%, 4% and 15% were used respectively for the hydro, diesel and natural gas units in the evaluation. Section 2 also presents results of basic generation adequacy evaluation of the WAF-MD system, in which the transmission lines are not considered. This approach is taken in LOLE evaluation of many large power systems, and LOLE of 0.1 days/year is often used as a capacity planning criterion. Using this criterion, the WAF-MD system can carry a peak load of

94.36 MW. An LOLE of 0.1 days/year was found to be equivalent to LOLE of 0.5 hours/year for the WAF-MD system without considering transmission constraints. It should be noted that the Aishihik hydro capacity limitation due to the line L171 was considered in the WAF system reliability criterion of LOLE = 2 hours/year.

The impact on the YEC adequacy of the major transmission line outages is analyzed and presented in Section 3. The studies show that the line L171 (connecting Ashihik) has the largest impact on the LOLE and LOEE results. The parallel lines L172 and the distribution lines connecting Takhini and Whitehorse also showed notable impact on the system indices. The lines L176, L174+L173 and L170 connect the Mayo hydro generation to the bulk system load at Whitehorse, and the impact of these lines increases with their proximity to Whitehorse area load. However, the lines L177 (connecting Dawson) and Line L178 (connecting Faro) have very little impact on the system indices, and therefore, need not be considered in the generation adequacy model of the system.

Five different generation adequacy models were developed for the WAF-MD system and presented in Section 4, based on the analyses of the results obtained in the Section 3 studies. The five generation adequacy models are arranged in the report in the order such that the amount of input data requirements and evaluation complexity increases from Models 1 to 5 in the list. In this order, the models also deviate further away from a basic generation capacity adequacy model or HLI (Hierarchical Level I) model towards a composite generation and transmission adequacy or HLII (Hierarchical Level II) model. LOLE evaluation was also done using a sixth model, the HLII model, and compared with the previous 5 different adequacy models. A comparative analysis of the results from the 6 different adequacy models suggest that the “Hydro Plants Interconnection Model” is a suitable generation adequacy model for the YEC system since it is relatively simple and provides reasonable results. This adequacy model was therefore incorporated in the program YESREL.

Section 5 presents results from selected case studies of potential future scenarios. The results show that the existing WAF-MD system can carry a peak load of 82.8 MW at the LOLE criterion of 2 hours/year. Including the mobile diesel units and YECL generation, the system can up to 91.4 MW of peak load. This would have reduced to 84.3 MW if the YEC had not installed the distribution

line to add redundancy to the line L172. As the system peak load is around 83 MW, the YEC/YECL system has adequate capacity to meet the short term load growth. This scenario will change in 2021 as two YEC diesel units (FD1 and WD3) retire. This will cause a capacity deficit as the YEC/YECL will only be able to carry a peak of 81.8 MW. If 25 MW capacity assistance can be provided through the Skagway line, the YEC/YECL system will be able to carry a peak load of 109.9 MW. When all the YEC diesel units retire in 2026, the YEC/YECL system will only be able to carry a peak load of 56.3 MW. Twinning the line L171 will raise the peak load carrying capability to 71.2 MW. A firm purchase of 25 MW through the Skagway line will enable the system to carry a peak load of 85.3 MW. Additional generation capacity installation will be required to meet the LOLE criterion of 2 hours/year in the year 2026. Representative data taken from the CEA Equipment Reliability Information System have been used to supplement the data provided by YEC. It should be noted that the study results are highly dependent on the generating unit and transmission line failure and repair parameters used in the analyses.

# TABLE OF CONTENTS

|   | Page |
|---|------|
| 1. Introduction   | 6    |
| 2. Basic Adequacy Evaluation  | 8    |
| 2.1 System Generation Data  | 9    |
| 2.2 System Load Data  | 14   |
| 2.3 System Evaluation and Models  | 17   |
| 2.4 Selected Task 1 Studies   | 25   |
| 3. Impact of Transmission Line Outage on Generation System Adequacy                       | 30   |
| 3.1 Major Transmission Line Data  | 31   |
| 3.2 Local Load Data   | 34   |
| 3.3 System Risk Evaluation Considering Line Outages                                       | 35   |
| 4. Development of Generating System Adequacy Model Considering Major Delivery Constraints | 39   |
| 4.1 Analysis of Alternate Generation Adequacy Models                                      | 39   |
| 4.2 Adequacy Evaluation Results from Alternate Models                                     | 44   |
| 4.3 Comparative Analysis of Alternate Models  | 54   |
| 5. Case studies considering Potential System Scenarios                                    | 58   |
| 5.1 Considering Existing Generation Facilities  | 60   |
| 5.2 Considering Unit Retirement Scenario in the Year 2021                                 | 64   |
| 5.3 Considering Unit Retirement Scenario in the Year 2026                                 | 65   |
| References  | 67   |

# 1. INTRODUCTION

This report presents the results of generation system adequacy evaluation studies of the Yukon Energy Corporation (YEC) electric system considering the major power delivery constraints in order to assist with the update of their 20-Year Resource Plan. The University of Saskatchewan conducted a reliability evaluation of the Whitehorse-Ashihik-Faro (WAF) electric power system in 2005 [1], and developed a software tool named WAFSREL [2] that incorporates the generation adequacy model developed in the 2005 study. There have since been significant changes to the topology and the configuration of the YEC system. The northern Mayo-Dawson (MD) system was interconnected to the southern WAF system through the Carmacks-Stewart transmission line. The University of Saskatchewan conducted a reliability evaluation of the extended Whitehorse-Ashihik-Faro-Mayo-Dawson (WAF-MD) electric power system in 2011 [3], and indicated that the WAFSREL program required relevant modification to incorporate the changes in the YEC electric power system. There have been further changes to generation capacity at various locations in the WAF and MD systems. This report also includes investigative studies to determine an appropriate generation adequacy evaluation model of the YEC electric power system to incorporate in the modified software tool.

Probabilistic reliability evaluation techniques [4] will be used in the overall project to carry out a number of case studies, and analyze the results to recommend an appropriate generation adequacy model for the YEC system under the changed scenario. The basic elements in a capacity adequacy review are the installed generating capacity and the system load. The YEC system load is dominated by the Whitehorse area load. Transmission lines are not generally considered in the generation capacity adequacy evaluation. Specific transmission facility that connects the power system to a remotely located large generation plant with insignificant local load are however typically considered in generation adequacy study. This approach will also be considered in the study to consider the ability of the remote generation at Aishihik, Faro, Mayo and Dawson to deliver their capacity to the Whitehorse load through the respective transmission lines. The impacts of major transmission line constraints in delivering the system generation capacity to the Whitehorse area were assessed in the study.

The project was carried out in five tasks. The first task was to carry out a basic generating capacity adequacy assessment of the YEC system considering the existing generation and load data. The transmission constraints to deliver the power to the system load were not considered in this task. The work in this task provides a base case to conduct comparative studies done in the next task to evaluate the impact of transmission lines. The second task was to evaluate the YEC system using a conditional probabilistic approach to assess the impact of the forced outages of major transmission lines on the generating capacity adequacy. The results of Task 2 studies were analyzed to quantitatively compare the impacts on the system adequacy of the individual transmission lines in order to assess their significance in the development of the system capacity adequacy model. The third task is to incorporate the constraints of all major transmission lines in the generating capacity adequacy evaluation of the YEC system, and determine an appropriate generation adequacy model for the YEC system. A number of case studies will be carried out in Task 4 using the transmission line constrained generating capacity adequacy model developed in Task 3. The final task is to develop a graphical user interface software tool that incorporates the transmission line constrained generating capacity adequacy model developed in Task 3.

A wide range of indices have been developed to quantify the reliability of electric power systems. These indices are described in detail in [4]. The basic concepts used to obtain the results provided in this report are also discussed and illustrated in [4]. The Loss of Load Expectation (LOLE), the Loss of Energy Expectation (LOEE), and the Peak Load Carrying Capability (PLCC) are the most commonly used indices in generating capacity reliability evaluation. The LOLE is the expected number of days or hours in the specified period when the load exceeds the available generating capacity. It is the most widely used index. The LOEE is the expected energy not served as a result of system generating capacity inadequacy. The PLCC is the peak load that the power system can carry while meeting the adequacy criterion. A LOLE of 2 hours/year is the accepted criterion adopted by YEC for generation planning.

## 2. BASIC ADEQUACY EVALUATION

This section presents a description of the relevant data, evaluation models and results obtained from a basic generating capacity adequacy assessment of the current YEC system using the conceptual reliability model [4] shown in Figure 2.1.

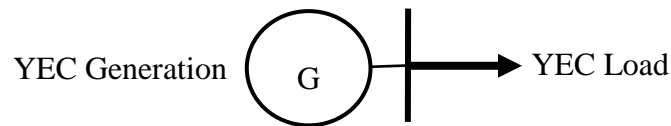

Figure 2.1: Basic Generation Adequacy Evaluation Model

The objective of the basic generation adequacy evaluation is to assess if an electric power system has sufficient generation facilities to meet the projected system demand within acceptable risk. This study does not consider the ability of the transmission system to deliver the power to the system load. A system generation model is created in the form of a discrete probability distribution by combining all the generating units in the system. A system load model is developed from the annual load profile of the entire power system. The line losses are included in the system load. The generation model and the load model are convolved to obtain quantitative risk indices. The loss of load expectation (LOLE) and the loss of energy expectation (LOEE) are the two important generation adequacy indices that will be used to quantify the level of system reliability. The peak load carrying capability (PLCC) of the generating system at the LOLE criterion of 2 hours per year will also be evaluated in the study. The results obtained from this study will be used to benchmark and compare the results obtained from the studies in the subsequent tasks.

## 2.1 System Generation Data

The YEC system generation data used in the study is shown in Table 2.1. The maximum continuous rating (MCR), generation type, location of the generation plants, and the total plant capacity are shown in the table.

Table 2.1: YEC System Generation Data

| Location    | Unit Type | Unit ID | MCR (MW) | Plant Capacity (MW) |        |
|-------------|-----------|---------|----------|---------------------|--------|
|             |           |         |          | Summer              | Winter |
| Whitehorse  | Hydro     | WH1     | 5.8      | 38.0                | 24.5   |
|             |           | WH2     | 5.8      |                     |        |
|             |           | WH3     | 8.4      |                     |        |
|             |           | WH4     | 20       |                     |        |
|             | Diesel    | WD3     | 4.5      | 15.0                | 15.0   |
|             |           | WD4     | 2.5      |                     |        |
|             |           | WD5     | 2.5      |                     |        |
|             |           | WD6     | 2.5      |                     |        |
|             |           | WD7     | 3.0      |                     |        |
| Natural Gas | WG1       | 4.4     | 8.8      | 8.8                 |        |
|             | WG2       | 4.4     |          |                     |        |
| Aishihik    | Hydro     | AH1     | 15       | 37.0                | 37.0   |
|             |           | AH2     | 15       |                     |        |
|             |           | AH3     | 7        |                     |        |
| Faro        | Diesel    | FD1     | 4.0      | 6.8                 | 6.8    |
|             |           | FD7     | 2.8      |                     |        |
| Mayo        | Hydro     | MH1     | 2.55     | 11.6                | 9.0    |
|             |           | MH2     | 2.55     |                     |        |
|             |           | MBH1    | 5.0      |                     |        |
|             |           | MBH2    | 5.0      |                     |        |
|             | Diesel    | FD2     | 0.85     | 2.55                | 2.55   |
|             |           | FD3     | 0.85     |                     |        |
|             |           | FD4     | 0.85     |                     |        |
| Dawson      | Diesel    | DD1     | 0.72     | 5.96                | 5.96   |
|             |           | DD2     | 0.92     |                     |        |
|             |           | DD3     | 0.92     |                     |        |
|             |           | FD5     | 1.0      |                     |        |
|             |           | DD5     | 1.4      |                     |        |
|             |           | FD6     | 1.0      |                     |        |

The total MCR in the above table is 131.21 MW. The total effective summer and winter capacities are 125.71 MW and 109.61 MW respectively. The winter season was considered to consist of the months from November to March, with the remaining months grouped into the summer category. The effective capacity of the Whitehorse and Mayo hydro plants during the winter season is limited to 24.5 MW and 9.0 MW respectively due to seasonal hydrological constraints. The effective capacity of the Whitehorse and Mayo hydro plants during the summer season is limited to 38.0 MW and 11.6 MW respectively due to water spilling requirements.

Table 2.2 shows an analysis of the forced outage rate (FOR) [4] data provided by YEC on all of their generating units. The generating units have been classified into 4 groups based on their types and sizes in the analysis. A five-year average FOR is calculated for each classification using the YEC data.

The FOR is the expected probability that the generating unit will not be available for service due to random failure, and is calculated using Equation 2.1 [5]. The utilization forced outage probability (UFOP) [4] is the appropriate parameter to represent the unavailability of a peaking unit that is only operated during the peak hours of the day. The UFOP is calculated using Equation 2.2 [5].

$$\text{FOR} = \frac{\text{FO} + \text{FEMO} + \text{FEPO}}{\text{FO} + \text{FEMO} + \text{FEPO} + \text{O} + \text{O}(\text{FD}) + \text{O}(\text{SD})} \times 100 \quad (2.1)$$

$$\text{UFOP} = \frac{f(\text{FO} + \text{FEMO} + \text{FEPO})}{f(\text{FO} + \text{FEMO} + \text{FEPO}) + \text{O} + \text{O}(\text{FD}) + \text{O}(\text{SD})} \times 100 \quad (2.2)$$

$$\text{Where } f = \text{demand factor} = \frac{\frac{1}{r} + \frac{1}{T}}{\frac{1}{r} + \frac{1}{T} + \frac{1}{D}},$$

and the durations,

FO = forced outage

FEMO = forced extension of maintenance outage

FEPO = forced extension of planned outage  
O = operating  
O(FD) = operating under a forced derating  
O(SD) = operating under a scheduled derating  
r = average repair time of the unit  
D = average in-service time per occasion of demand  
T = average reserve shutdown time between periods of need

Table 2.2: Analysis of YEC Generating Unit FOR Data

| Unit ID   | MCR (MW) | 2015  | 2014  | 2013  | 2012   | 2011   | Average |
|---|----------|-------|-------|-------|--------|--------|---------|
| <b>Large Hydro Units (with High Operating Factor)</b> |          |       |       |       |        |        |         |
| AH1   | 15       | 0.05% | -     | -     | 0.19%  | 0.06%  | 0.88%   |
| AH2   | 15       | 0.08% | 0.01% | 0.02% | -      | 0.01%  |         |
| AH3   | 7        | 0.58% | -     | -     | 1.69%  | -      |         |
| WH3   | 8.4      | 0.06% | 0.83% | -     | 0.79%  | 0.04%  |         |
| WH4   | 20       | 0.02% | 9.46% | -     | -      | 0.16%  |         |
| <b>Small Hydro Units</b>                              |          |       |       |       |        |        |         |
| MBH1  | 5        | 1.96% | 0.07% | 1.02% | 1.25%  | 2.18%  | 0.85%   |
| MBH2  | 5        | -     | 0.02% | 1.73% | 4.13%  | -      |         |
| MH1   | 2.55     | -     | -     | -     | 0%     | -      |         |
| MH2   | 2.55     | 0.03% | 0.07% | 0%    | -      | -      |         |
| WH1   | 5.8      | 0.02% | 0.83% | -     | 1.88%  | 0.01%  |         |
| WH2   | 5.8      | -     | 0.83% | 0.01% | 1.03%  | 0.01%  |         |
| <b>Diesel Units</b>                                   |          |       |       |       |        |        |         |
| DD1   | 0.72     | 0.15% | -     | -     | -      | -      | 3.72%   |
| DD2   | 0.92     | -     | -     | -     | 17.62% | 7.3%   |         |
| DD3   | 0.92     | -     | 0.01% | -     | -      | -      |         |
| DD5   | 1.4      | 0.55% | 0.01% | -     | 2.78%  | 0.21%  |         |
| FD2   | 0.85     | 0.33% | 0.01% | -     | -      | -      |         |
| FD3   | 0.85     | -     | 0.01% | -     | -      | 6.6%   |         |
| FD4   | 0.85     | -     | -     | -     | -      | 2.44%  |         |
| FD1   | 4        | 0.25% | 2.21% | 12.4% | 3.9%   | 7.22%  |         |
| FD7   | 2.8      | 0.25% | 0.34% | 0%    | 24.6%  | 8.3%   |         |
| WD3   | 4.5      | 0.59% | -     | -     | 0.6%   | 1.67%  |         |
| WD4   | 2.5      | 1.38% | -     | -     | -      | 0.01%  |         |
| WD5   | 2.5      | 1.4%  | 0%    | 0.01% | -      | 24.18% |         |
| WD6   | 2.5      | 1.48% | 0.15% | 0%    | 0.03%  | 9.54%  |         |
| WD7   | 3        | 2.67% | -     | -     | -      | -      |         |
| <b>Natural Gas Units</b>                              |          |       |       |       |        |        |         |
| WG1   | 4.4      | 0.18% | -     | -     | -      | -      | 0.64%   |
| WG2   | 4.4      | 1.1%  | -     | -     | -      | -      |         |

Table 2.3 shows the relevant FOR and UFOP data from the CEA-ERIS 2014 Generation Equipment Status Annual Report [5].

Table 2.3: CEA-2014 Generation Forced Outage Data [5]

| Size & Operating Factor | Hydro Unit, FOR              | Combustion Turbine, UFOP      |
|-------------------------|------------------------------|-------------------------------|
| Small units             | 9.70%<br>(5-23 MW, 607.5 uy) | 47.14%<br>(10-24 MW, 12.8 uy) |
| All sizes               | 5.03%, (2290.8 uy)           | 15.31%, (165.2 uy)            |
| Op. Factor below 10%    | 95.92%                       | 19.95%, (106.9 uy)            |
| Op. Factor 11-20%       | 64.49%                       | 16.29%, (5.0 uy)              |
| Op. Factor 21-30%       | 24.69%                       | 8.44%, (24.4 uy)              |
| Op. Factor 61-70%       | 1.23% (37.2 uy)              |                               |
| Op. Factor 71-80%       | 2.08% (65.2 uy)              |                               |
| Op. Factor 81-90%       | 1.40%, (669.8 uy)            |                               |
| Op. Factor above 90%    | 0.61%, (366.5 uy)            |                               |

Note: uy = units years

The YEC generation system includes hydraulic units, diesel engine units and natural gas combustion turbine units. The CEA report does not include diesel engine units. The YEC data for the diesel unit FOR was obtained from a population of 38 units years of data, and are used in the study. A review of YEC data and CEA data shown Tables 2.2 and 3.3 indicate that the YEC hydro unit FOR data are within the range of the CEA data for hydro units with high operating factors. As most YEC hydro units have high operating factors, the average of the actual YEC data is used in this study. There is very little YEC data on the forced outage of natural gas units. The CEA data for small combustion turbine units is skewed by the full outage of 3 units reported in the year 2014. The CEA UFOP data considering all operating factors and sizes of combustion turbine units calculated from a sample of 165.2 unit years are, therefore, used as representative data for natural gas combustion turbine in this study. Table 2.4 shows the generating unit FOR data used in the 2011 YEC report [3], the average FOR data obtained from actual YEC data collection, and the

FOR data used in the current reliability study. The FOR data used in this study are shown in the last column of Table 2.4.

Table 2.4: FOR Data for YEC Generating Units

| <b>Generating Unit</b> | <b>FOR (%)</b>             |                        |                            |
|------------------------|----------------------------|------------------------|----------------------------|
|                        | <b>2011 Study Data [3]</b> | <b>YEC Actual Data</b> | <b>Data for this study</b> |
| Hydro                  | 3.0                        | 0.9                    | 1.0                        |
| Diesel                 | 10.0                       | 3.7                    | 4.0                        |
| Natural Gas            | N/A                        | 0.6                    | 15.0                       |

## 2.2 System Load Data

Historical data on the total chronological hourly generation to meet the system load for the past five years were provided by YEC, and is shown in Figure 2.2.

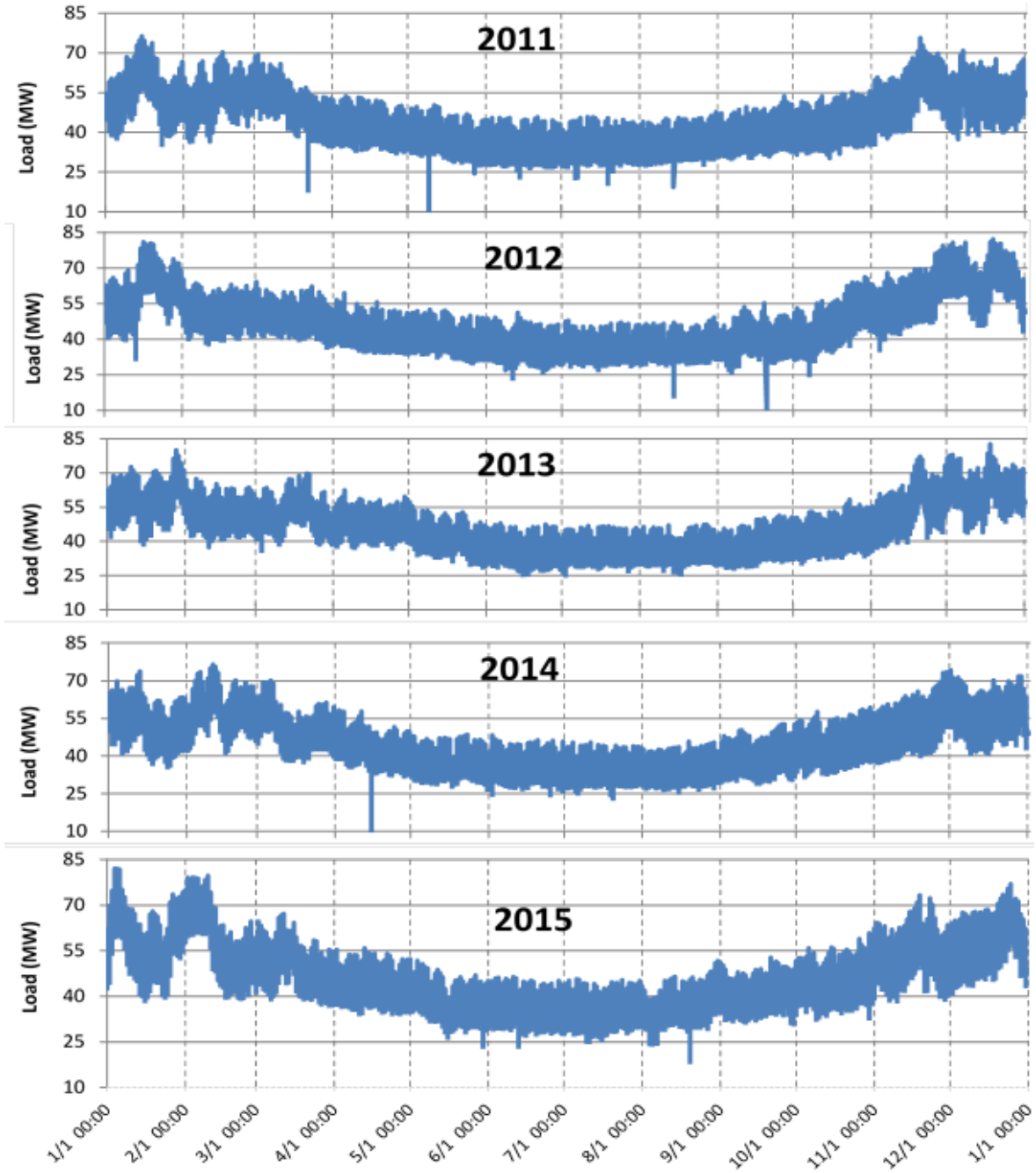

Figure 2.2: YEC Hourly Generation Data, 2011 – 2015

The sudden drops in generation in Figure 2.2 likely indicate data associated with loss of load events, and are therefore replaced by interpolated data. Figure 2.3 shows the modified chronological load data for the past 5 years.

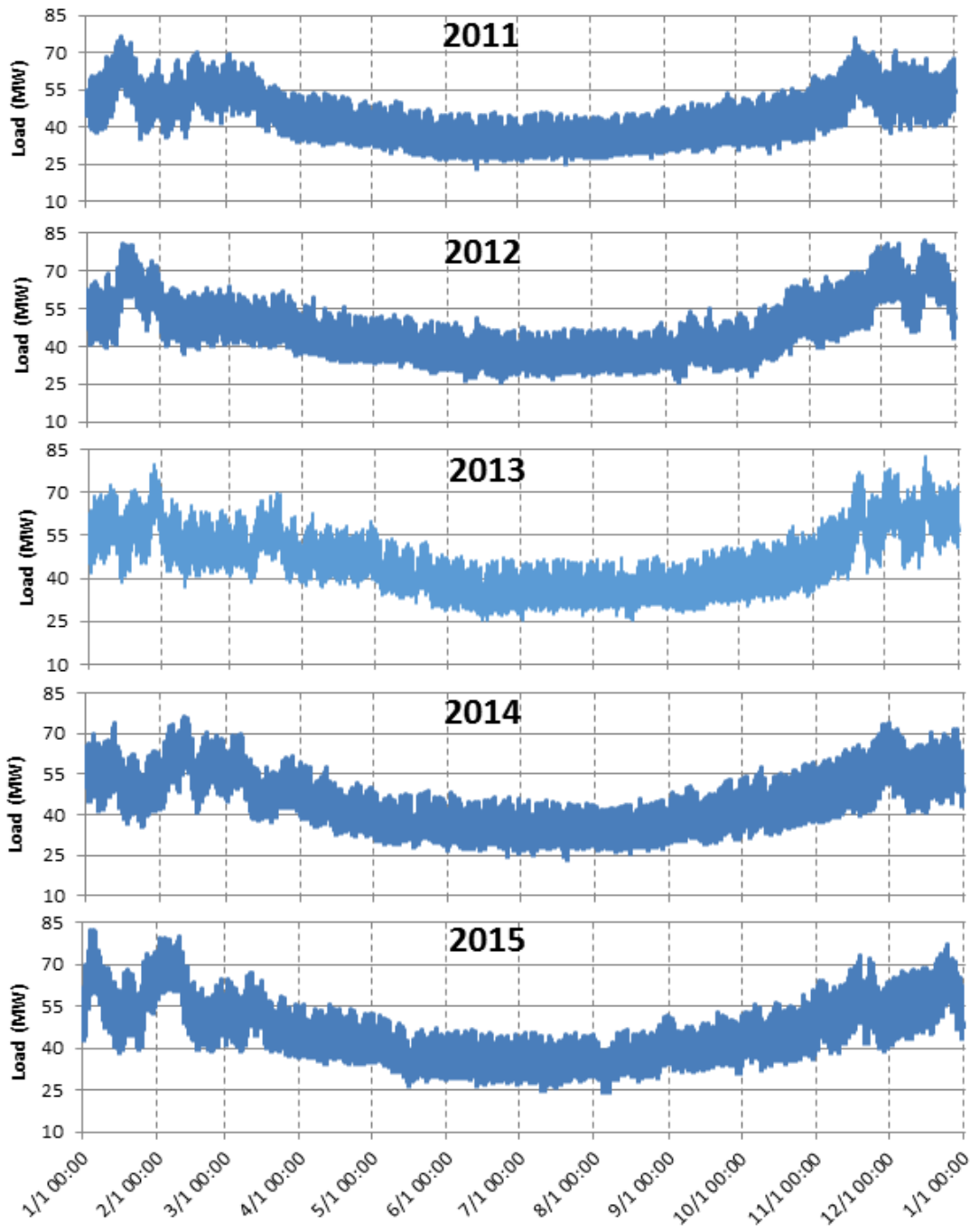

Figure 2.3. YEC Hourly Load Data for 2011-2015

The chronological load data were sorted in the decreasing order and expressed in per unit of the corresponding peak loads of the year to create the annual load duration curve (LDC) for each year. Data for the extra day in the leap year were not considered in the load model. Table 2.5 shows the annual peak load and the load factor for each year. Figure 2.4 shows the annual LDC for the 5 years. The average LDC was obtained by averaging the 5 LDC load points expressed in per unit of their respective peak loads that are arranged in the decreasing order. The average LDC can be used as a representative load model in reliability studies for system planning. The average LDC is also shown in the figure.

Table 2.5: Annual Peak Load and Load Factor

|                | 2011  | 2012  | 2013  | 2014  | 2015  | Average LDC |
|----------------|-------|-------|-------|-------|-------|-------------|
| Load Factor    | 60.1% | 58.9% | 58.2% | 60.8% | 57.9% | 58.3%       |
| Peak Load (MW) | 76.34 | 82.24 | 82.69 | 76.52 | 82.06 | -           |

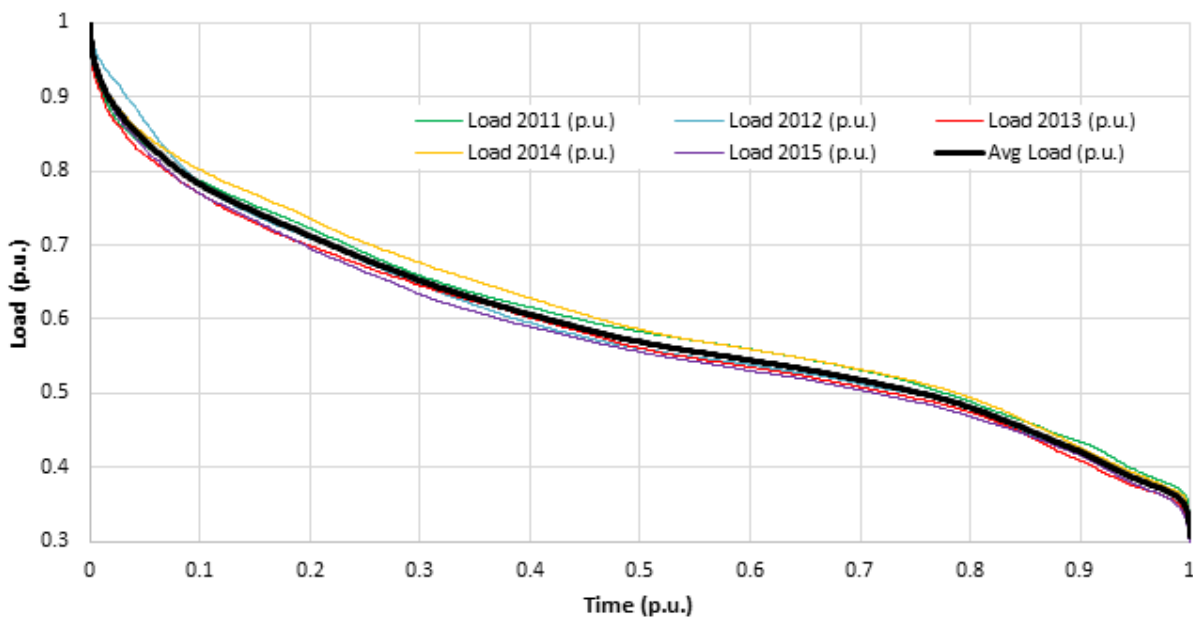

Figure 2.4. Annual Load Duration Curves, 2011 - 2015

## 2.3 System Evaluation and Models

A basic generating capacity adequacy evaluation was initially conducted for the YEC system using the model in Figure 2.1 without considering the seasonal capacity limitations of the Whitehorse and Mayo hydro plants. The generating unit data shown in the 4<sup>th</sup> and 5<sup>th</sup> columns of Table 2.1, and the outage data shown in the last column of Table 2.4 were used to create the overall system generation model. The annual LDCs were used as the system load model. The system LOLE were calculated for a range of peak loads using the average and the five LDCs for each of the past years. The LOLE results are shown in Table 2.6 and Figure 2.5.

Table 2.6: System LOLE Obtained Using the Load Models for the Different Years

| Peak Load (MW) | LOLE (h/yr) with Load Model from Year |        |        |        |        |         |
|----------------|---------------------------------------|--------|--------|--------|--------|---------|
|                | 2011                                  | 2012   | 2013   | 2014   | 2015   | Average |
| 74.00          | 0.0000                                | 0.0000 | 0.0000 | 0.0000 | 0.0000 | 0.0000  |
| 76.34          | 0.0000                                | 0.0001 | 0.0000 | 0.0000 | 0.0000 | 0.0000  |
| 78.00          | 0.0000                                | 0.0001 | 0.0000 | 0.0001 | 0.0001 | 0.0000  |
| 80.00          | 0.0001                                | 0.0002 | 0.0001 | 0.0001 | 0.0001 | 0.0001  |
| 82.06          | 0.0002                                | 0.0004 | 0.0001 | 0.0002 | 0.0002 | 0.0002  |
| 84.00          | 0.0003                                | 0.0007 | 0.0002 | 0.0004 | 0.0004 | 0.0004  |
| 86.00          | 0.0006                                | 0.0015 | 0.0005 | 0.0008 | 0.0008 | 0.0008  |
| 88.00          | 0.0012                                | 0.0030 | 0.0009 | 0.0017 | 0.0016 | 0.0015  |
| 90.00          | 0.0023                                | 0.0060 | 0.0019 | 0.0033 | 0.0033 | 0.0030  |
| 92.00          | 0.0046                                | 0.0120 | 0.0036 | 0.0064 | 0.0063 | 0.0059  |
| 94.00          | 0.0085                                | 0.0220 | 0.0067 | 0.0120 | 0.0116 | 0.0110  |
| 96.00          | 0.0153                                | 0.0387 | 0.0120 | 0.0213 | 0.0202 | 0.0196  |
| 98.00          | 0.0267                                | 0.0644 | 0.0209 | 0.0368 | 0.0343 | 0.0336  |
| 100.00         | 0.0442                                | 0.1046 | 0.0358 | 0.0618 | 0.0570 | 0.0562  |
| 102.00         | 0.0741                                | 0.1708 | 0.0604 | 0.1027 | 0.0961 | 0.0932  |

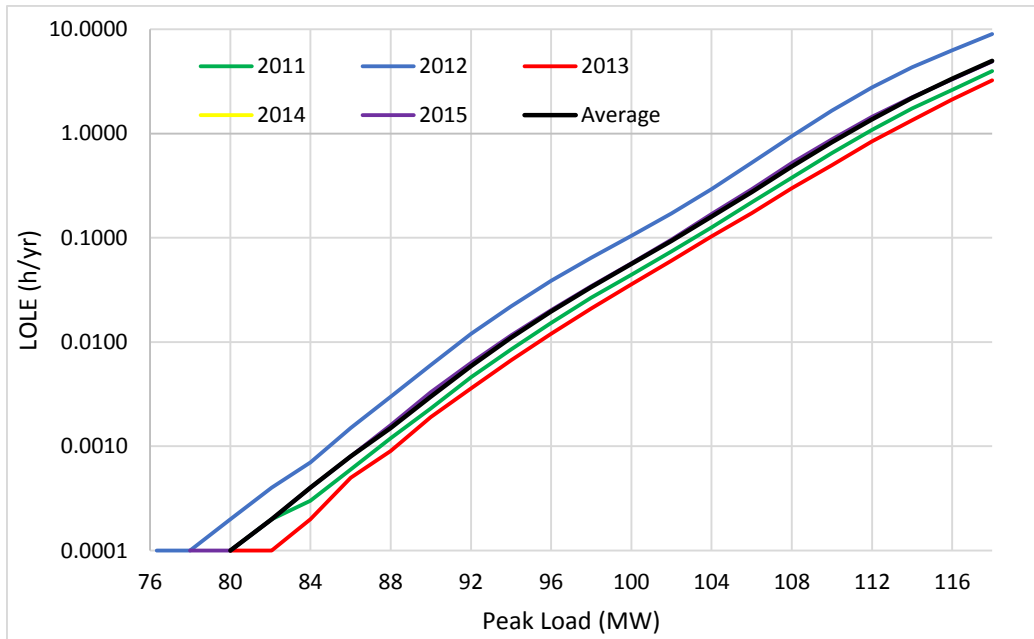

Figure 2.5: System LOLE Obtained Using the Load Models for the Different Years

A comparison of the LOLE results shown in Table 2.26 and Figure 2.5 indicates that there is insignificant difference in the results obtained using the 2015 load model and the average load model. The 2015 load model can therefore be used instead of the average load model in adequacy study. It should however be noted that the above results do not consider the seasonal hydro capacity constraints, which can have significant impact on the LOLE and LOEE indices.

It was shown in the 2011 report [3] that the reliability indices calculated for the winter period were practically the same as those calculated for the entire year, since the summer indices were insignificant relative to the annual indices. A comparative adequacy study similar to the one discussed above using the load models for the different years was next carried out for the winter period recognizing the seasonal hydro capacity limitations. The 5 months between the months of November and March were considered in the winter period. The generating unit data shown in the 4<sup>th</sup> and 6<sup>th</sup> columns of Table 2.1 were used to create the overall system generation model in this case. The winter LDCs were used as the system load model. Figure 2.6 shows the winter LDC for the 5 years. The average winter LDC is also shown in the figure.

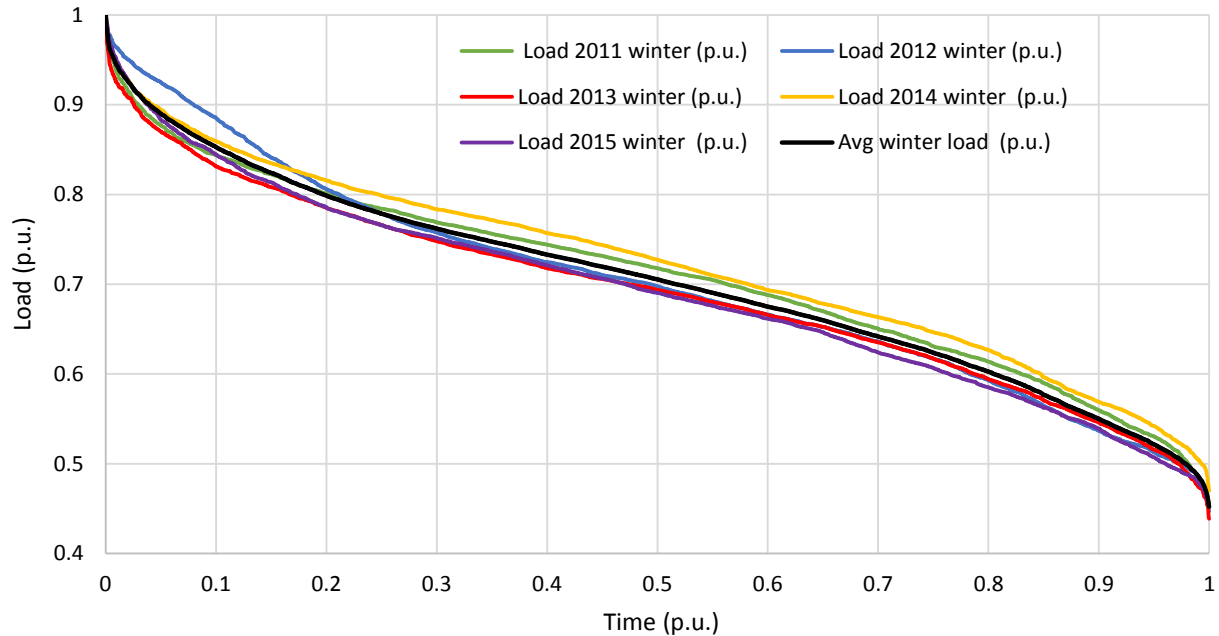

Figure 2.6. Winter Load Duration Curves, 2011 - 2015

The system LOLE and LOEE were calculated for the range of peak loads using the average winter LDC and the five winter LDCs for each of the past years. The results are shown in Table 2.7 and 2.8 respectively. The results shown in bold font are the system LOLE and LOEE obtained from HL-I generation adequacy evaluation in the past five years assuming that the same amount of system capacity existed in the past five years. The system LOLE and LOEE are also shown as a function of the system peak loads in Figures 2.6 and 2.7 respectively.

Table 2.7: Winter LOLE Obtained Using the Winter Load Models for the Different Years

| Peak Load (MW) | LOLE (h/yr) with Load Model from Year |               |        |               |               |         |
|----------------|---------------------------------------|---------------|--------|---------------|---------------|---------|
|                | 2011                                  | 2012          | 2013   | 2014          | 2015          | Average |
| 74.00          | 0.0003                                | 0.0008        | 0.0002 | 0.0004        | 0.0004        | 0.0003  |
| 76.34          | <b>0.0008</b>                         | 0.0021        | 0.0006 | 0.0011        | 0.0011        | 0.0010  |
| 76.52          | 0.0008                                | 0.0023        | 0.0006 | <b>0.0012</b> | 0.0012        | 0.0011  |
| 78.00          | 0.0015                                | 0.0042        | 0.0012 | 0.0021        | 0.0021        | 0.0020  |
| 80.00          | 0.0031                                | 0.0083        | 0.0025 | 0.0045        | 0.0043        | 0.0041  |
| 82.06          | 0.0063                                | 0.0158        | 0.0052 | 0.0088        | <b>0.0084</b> | 0.0082  |
| 82.24          | 0.0067                                | <b>0.0167</b> | 0.0054 | 0.0094        | 0.0089        | 0.0086  |

Table 2.7 Continued..

| Peak Load (MW) | LOLE (h/yr) with Load Model from Year |        |               |        |        |         |
|----------------|---------------------------------------|--------|---------------|--------|--------|---------|
|                | 2011                                  | 2012   | 2013          | 2014   | 2015   | Average |
| 82.69          | 0.0078                                | 0.0193 | <b>0.0063</b> | 0.0110 | 0.0103 | 0.0100  |
| 84.00          | 0.0119                                | 0.0283 | 0.0095        | 0.0164 | 0.0154 | 0.0150  |
| 86.00          | 0.0222                                | 0.0518 | 0.0180        | 0.0308 | 0.0292 | 0.0281  |
| 88.00          | 0.0435                                | 0.1026 | 0.0347        | 0.0601 | 0.0587 | 0.0544  |
| 90.00          | 0.0851                                | 0.2132 | 0.0663        | 0.1186 | 0.1165 | 0.1077  |
| 92.00          | 0.1686                                | 0.4443 | 0.1330        | 0.2445 | 0.2475 | 0.2211  |
| 94.00          | 0.3306                                | 0.9074 | 0.2589        | 0.4684 | 0.4702 | 0.4298  |
| 96.00          | 0.6215                                | 1.6439 | 0.4854        | 0.8869 | 0.8643 | 0.8106  |
| 98.00          | 1.1111                                | 2.8445 | 0.8620        | 1.5365 | 1.4583 | 1.4230  |
| 100.00         | 1.8836                                | 4.5430 | 1.4896        | 2.5907 | 2.3792 | 2.3610  |
| 102.00         | 3.0270                                | 6.9955 | 2.4571        | 4.1931 | 3.7970 | 3.8259  |

Table 2.8: Winter LOEE Obtained Using the Winter Load Models for the Different Years

| Peak Load (MW) | LOEE (MWh/yr) with Load Model from Year |               |              |              |               |           |
|----------------|---|---------------|--------------|--------------|---------------|-----------|
|                | 2011                                    | 2012          | 2013         | 2014         | 2015          | Average   |
| 74.00          | 0.455                                   | 1.409         | 0.353        | 0.672        | 0.743         | 0.626     |
| 76.34          | <b>1.479</b>                            | 4.392         | 1.153        | 2.156        | 2.301         | 2.009     |
| 76.52          | 1.611                                   | 4.767         | 1.256        | <b>2.349</b> | 2.501         | 2.187     |
| 78.00          | 3.178                                   | 9.172         | 2.467        | 4.584        | 4.776         | 4.265     |
| 80.00          | 7.34                                    | 20.55         | 5.7          | 10.502       | 10.625        | 9.738     |
| 82.06          | 16.105                                  | 43.287        | 12.631       | 22.866       | <b>22.478</b> | 21.157    |
| 82.24          | 17.184                                  | <b>46.042</b> | 13.506       | 24.383       | 23.93         | 22.553    |
| 82.69          | 20.179                                  | 53.601        | <b>15.94</b> | 28.611       | 27.948        | 26.419    |
| 84.00          | 31.788                                  | 82.361        | 25.383       | 44.982       | 43.453        | 41.366    |
| 86.00          | 61.946                                  | 155.231       | 49.45        | 87.25        | 83.278        | 79.845    |
| 88.00          | 119.32                                  | 293.757       | 96.635       | 168.256      | 162.524       | 153.31    |
| 90.00          | 231.97                                  | 578.792       | 186.271      | 327.567      | 321.692       | 297.742   |
| 92.00          | 459.246                                 | 1170.738      | 367.208      | 650.56       | 654.127       | 592.165   |
| 94.00          | 915.212                                 | 2406.732      | 714.218      | 1291.858     | 1306.969      | 1181.117  |
| 96.00          | 1783.406                                | 4754.472      | 1385.115     | 2512.84      | 2532.747      | 2308.01   |
| 98.00          | 3357.635                                | 8934.562      | 2591.212     | 4729.239     | 4667.780      | 4353.359  |
| 100.00         | 6027.934                                | 15814.727     | 4731.525     | 8474.082     | 8208.876      | 7802.765  |
| 102.00         | 10405.983                               | 26430.469     | 8253.050     | 14621.479    | 13840.248     | 13426.747 |

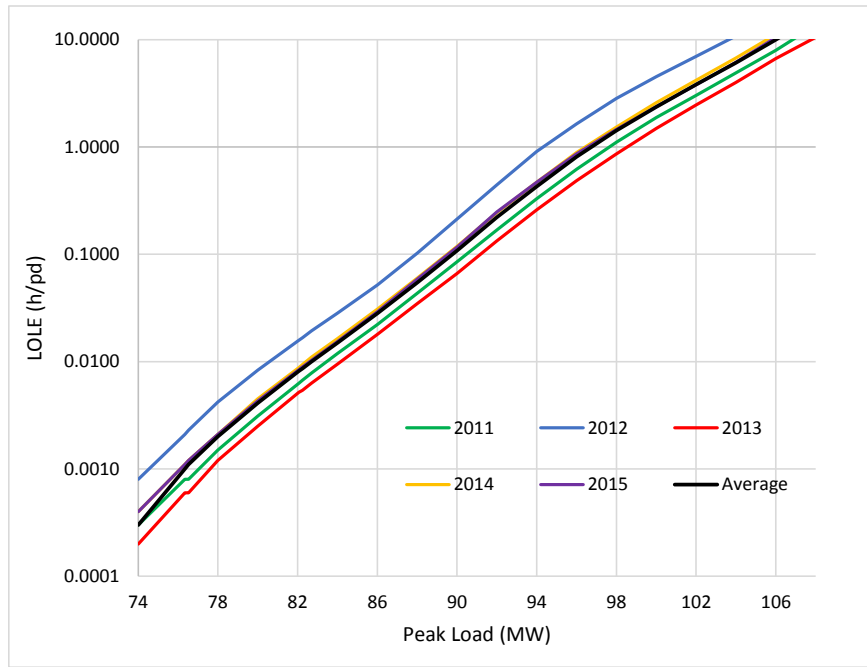

Figure 2.6: Winter LOLE Obtained Using the Winter Load Models for the Different Years

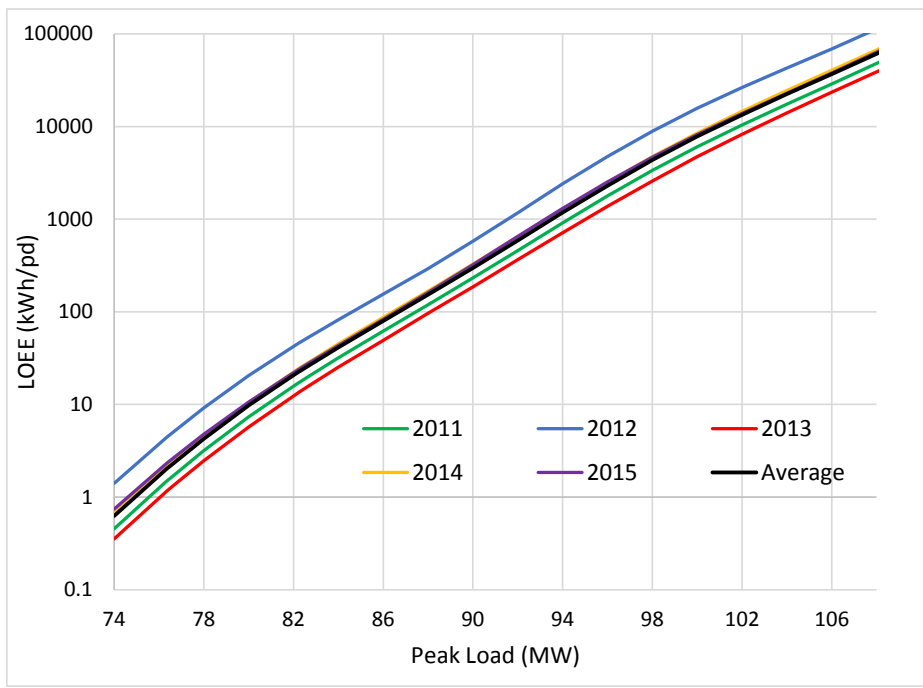

Figure 2.7: Winter LOEE Obtained Using the Winter Load Models for the Different Years

A comparison of the LOLE and LOEE results shown in Figures 2.6 and 2.7 indicates that there is insignificant difference in the results obtained using the 2015 winter load model and the average winter load model. The 2015 load shape can therefore be used as a representative load profile for the YEC adequacy study.

It should be noted from the comparison of the LOLE results in Tables 2.5 and 2.6 that the system LOLE are substantially increased when winter capacity limitations are incorporated in the evaluation. An annual assessment done without considering seasonal capacity limitations result in highly optimistic LOLE indices. It is therefore necessary to carry out period analysis that recognizes the seasonal capacity constraints of the hydro plants.

A period analysis was next carried out considering the seasonal hydro capacity constraints. A study year was divided into two periods; (1) winter period from November to March and (2) summer period between April to October. Separate generation and load models were created for each period. The winter and summer load models obtained from the 2015 load data were used in the study, and are shown in Figure 2.8. The reliability indices calculated for each period were then aggregated to obtain the overall annual indices. The results are shown in Table 2.9.

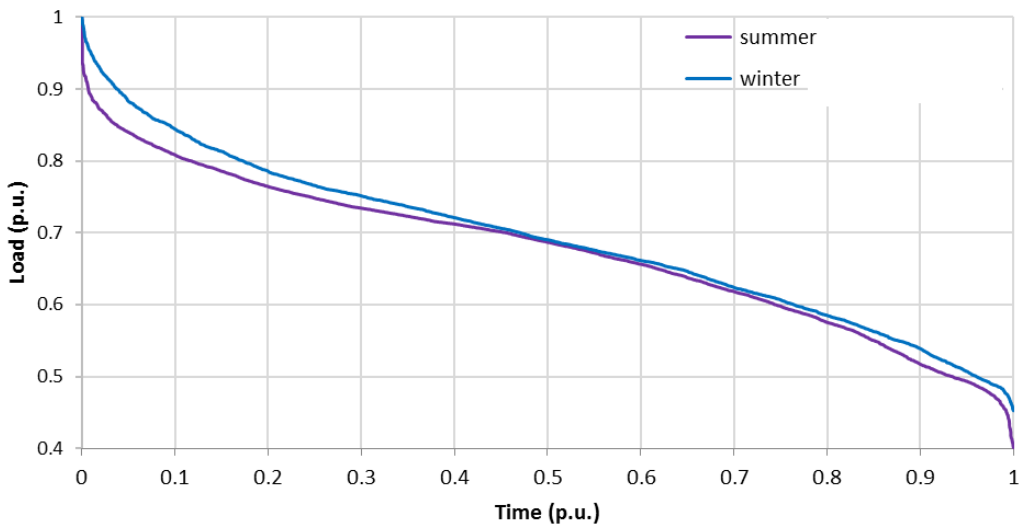

Figure 2.9: Winter and Summer Load Models in Per Unit of their Respective Peaks

Table 2.9: LOLE and LOEE Results from Period Analysis

| Peak Load (MW) | LOLE (h/pd) |         |         |        | LOEE (MWh/pd) |         |         |        |
|----------------|-------------|---------|---------|--------|---------------|---------|---------|--------|
|                | Summer      | Winter  | Annual  | Error  | Summer        | Winter  | Annual  | Error  |
| 74             | 0.0000      | 0.0004  | 0.0004  | 0.00%  | 0.0000        | 0.0007  | 0.0007  | -0.13% |
| 76             | 0.0000      | 0.0010  | 0.0010  | 0.00%  | 0.0000        | 0.0020  | 0.0020  | -0.25% |
| 78             | 0.0000      | 0.0021  | 0.0021  | 0.00%  | 0.0000        | 0.0048  | 0.0048  | -0.35% |
| 80             | 0.0000      | 0.0043  | 0.0043  | 0.00%  | 0.0000        | 0.0106  | 0.0107  | -0.46% |
| 82             | 0.0001      | 0.0082  | 0.0083  | -1.20% | 0.0001        | 0.0220  | 0.0221  | -0.56% |
| 84             | 0.0001      | 0.0154  | 0.0155  | -0.65% | 0.0003        | 0.0435  | 0.0437  | -0.64% |
| 86             | 0.0002      | 0.0292  | 0.0294  | -0.68% | 0.0006        | 0.0833  | 0.0839  | -0.72% |
| 88             | 0.0005      | 0.0587  | 0.0592  | -0.84% | 0.0012        | 0.1625  | 0.1638  | -0.75% |
| 90             | 0.0009      | 0.1165  | 0.1174  | -0.77% | 0.0024        | 0.3217  | 0.3241  | -0.75% |
| 92             | 0.0018      | 0.2475  | 0.2493  | -0.72% | 0.0048        | 0.6541  | 0.6589  | -0.72% |
| 94             | 0.0032      | 0.4702  | 0.4734  | -0.68% | 0.0091        | 1.3070  | 1.3161  | -0.69% |
| 96             | 0.0061      | 0.8643  | 0.8704  | -0.70% | 0.0172        | 2.5327  | 2.5499  | -0.67% |
| 98             | 0.0109      | 1.4583  | 1.4692  | -0.74% | 0.0321        | 4.6678  | 4.6999  | -0.68% |
| 100            | 0.0194      | 2.3792  | 2.3986  | -0.81% | 0.0582        | 8.2089  | 8.2671  | -0.70% |
| 102            | 0.0338      | 3.7970  | 3.8308  | -0.88% | 0.1042        | 13.8402 | 13.9445 | -0.75% |
| 104            | 0.0564      | 6.1686  | 6.2250  | -0.91% | 0.1818        | 22.9164 | 23.0981 | -0.79% |
| 106            | 0.0940      | 10.4473 | 10.5413 | -0.89% | 0.3123        | 37.8679 | 38.1802 | -0.82% |

It can be observed from Table 2.9 that the winter LOLE and LOEE are proximately equal to the annual LOLE and LOEE, and the error between the winter and annual indices as shown in the table are insignificant for all practical purposes. The LOLE and LOEE results are also shown in Figures 2.10 and 2.11 respectively. The peak load carrying capability (PLCC) of the YEC system at a LOLE criterion of 2.0 h/yr was also calculated using the period analysis. The PLCC considering both the summer and winter periods was found to be 99.22 MW. The PLCC obtained using only the winter models was 99.25 MW. It can therefore be concluded that the winter indices obtained using the winter generation and load models can be used to represent the annual indices in generation adequacy evaluation of the YEC system.

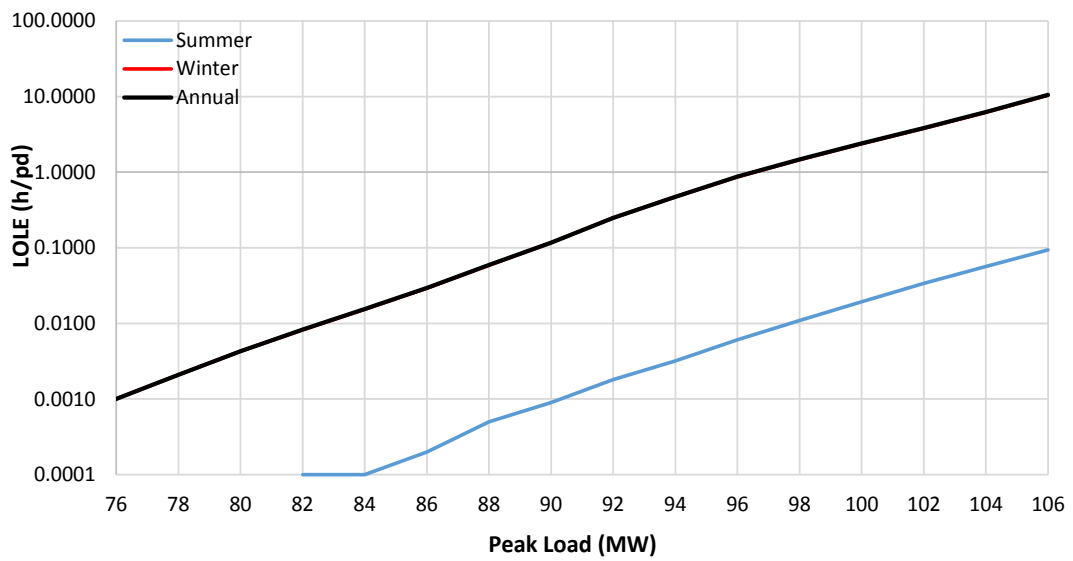

Figure 2.10: Summer, Winter and Annual System LOLE

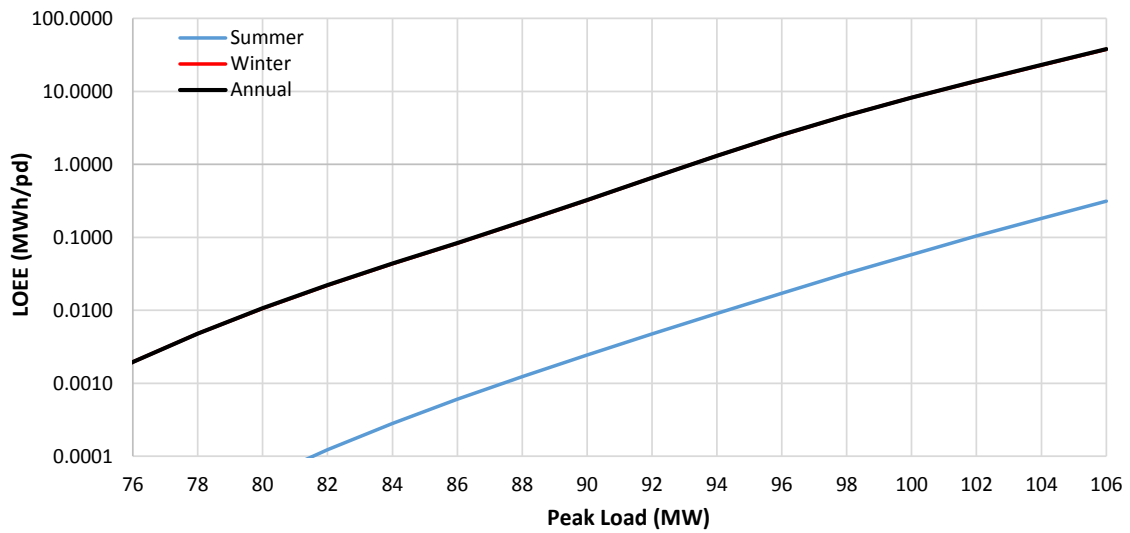

Figure 2.11: Summer, Winter and Annual System LOEE

It should be noted that the adequacy evaluation results presented in this section do not consider the transmission system. This is the typical approach in large power systems that have balanced transmission networks. In such systems, an LOLE of 0.1 days per year is the recommended reliability criterion in capacity planning. A daily peak load variation curve (DPLVC) is used as the load model instead of the LDC when evaluating the LOLE in days per year. A DPLVC curve is obtained by sorting the daily peaks in the decreasing order, and the load model is shown in Figure 2.12. Using the LOLE of 0.1 days per year as the criterion, the PLCC of the YEC system was evaluated, and found to be 94.36 MW. The LOLE in hours per year is 0.52 h/yr at the peak load of 94.36 MW.

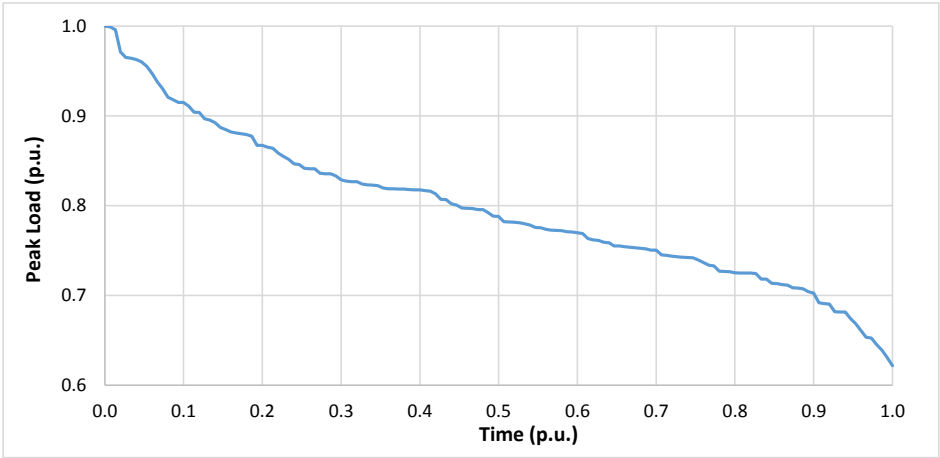

Figure 2.12: Year 2015 Winter DPLVC

### 2.4 Selected Task 1 Studies

As noted earlier, many large power systems conduct generation adequacy evaluation during generation planning, and these studies do not normally consider the transmission system. This type of evaluation is carried out in Task 1 using generating unit data from Table 2.1 and the forced outage data in the last column of Table 2.4. The hydro plant capacity limited by the winter water

conditions as shown in the 6<sup>th</sup> column of Table 2.1 are used in the evaluation. The 2015 winter LDC is used as the load model which includes the local loads and the line losses. The system LOLE and LOEE for a range of peak loads are shown in Table 2.9.

A FOR of 15% was used in the adequacy study based on the CEA data [5]. A study was also done assuming the Whitehorse natural gas units have the same FOR as the diesel generating units, which is 4%. The LOLE and LOEE results for a range of peak loads can be compared in Table 2.10. A comparison of the LOLE results is also shown in Figure 2.13.

Table 2.10: Impact of Natural Gas Unit FOR on Task-1 LOLE and LOEE Results

| Peak Load<br>(MW) | LOLE (h/yr) |         | LOEE (MWh/yr) |           |
|-------------------|-------------|---------|---------------|-----------|
|                   | FOR=15%     | FOR=4%  | FOR=15%       | FOR=4%    |
| 74                | 0.0004      | 0.0001  | 0.743         | 0.215     |
| 76                | 0.0010      | 0.0004  | 1.962         | 0.663     |
| 78                | 0.0021      | 0.0010  | 4.776         | 1.880     |
| 80                | 0.0043      | 0.0023  | 10.625        | 4.790     |
| 82.06             | 0.0084      | 0.0049  | 22.478        | 11.581    |
| 84                | 0.0154      | 0.0092  | 43.453        | 24.161    |
| 86                | 0.0292      | 0.0162  | 83.278        | 47.343    |
| 88                | 0.0587      | 0.0299  | 162.524       | 89.069    |
| 90                | 0.1165      | 0.0569  | 321.692       | 167.778   |
| 92                | 0.2475      | 0.1240  | 654.127       | 330.894   |
| 94                | 0.4702      | 0.2563  | 1306.969      | 673.851   |
| 96                | 0.8643      | 0.5405  | 2532.747      | 1396.100  |
| 98                | 1.4583      | 0.9747  | 4667.780      | 2793.316  |
| 100               | 2.3792      | 1.6655  | 8208.876      | 5250.518  |
| 102               | 3.7970      | 2.5858  | 13840.248     | 9172.959  |
| 104               | 6.1686      | 4.0635  | 22916.385     | 15253.594 |
| 106               | 10.4473     | 6.4940  | 37867.875     | 24757.285 |
| 108               | 17.5478     | 10.8929 | 63699.516     | 40629.656 |
| 110               | 29.6536     | 19.4732 | 106803.742    | 67901.023 |

The difference in PLCC using the two different FOR data for the natural gas units can be seen in Figure 2.13. The difference in PLCC at the LOLE criterion of 2 hours per year is 1.56 MW. The system PLCC results are shown in Table 2.11. The system PLCC at the LOLE criterion of 0.1 days per year is also shown in the table.

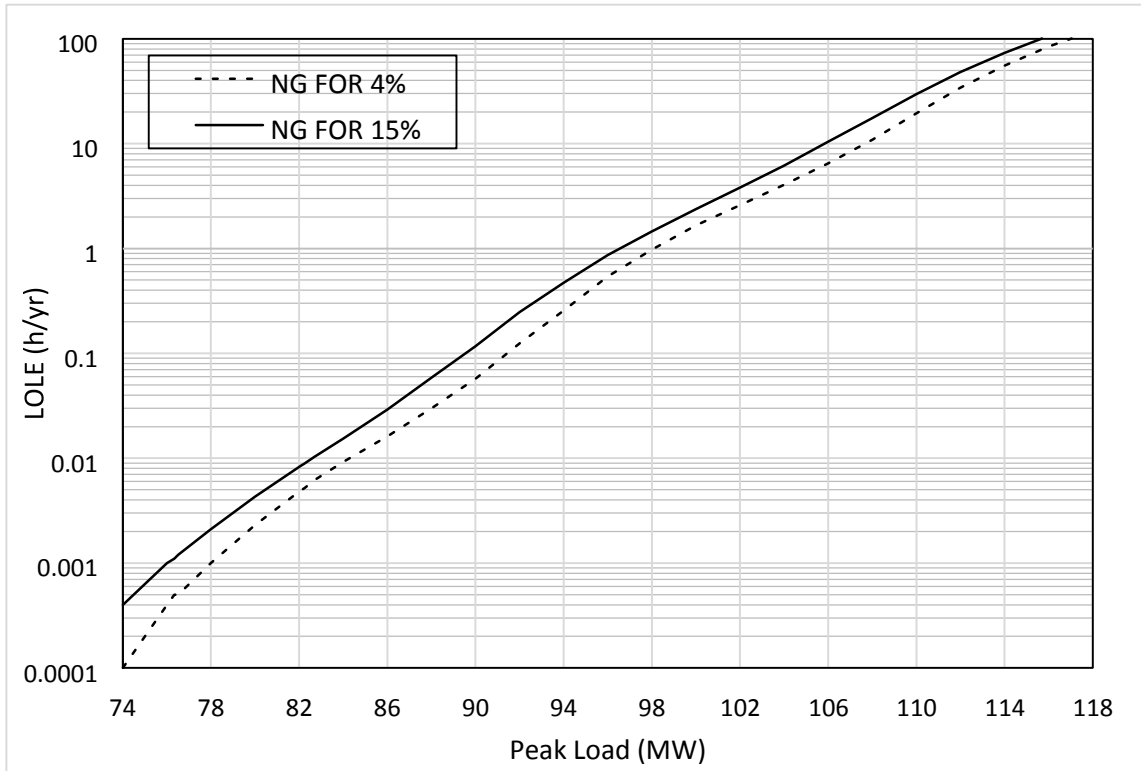

Figure 2.13: Comparison of the System LOLE Using Different FOR Data for the Natural Gas Units

Table 2.11: Comparison of System PLCC Using Different FOR Data for the Natural Gas Units

| LOLE Criterion | PLCC (MW) |          |
|----------------|-----------|----------|
|                | FOR=15%   | FOR=4%   |
| 2.0 h/yr       | 99.2487   | 100.8139 |
| 0.1 d/yr       | 94.3608   | 95.5425  |

The adequacy studies includes the YEC generation data shown in Table 2.1. A Task 1 generation adequacy study was also carried out including the ATCO/YECL diesel generating units shown in Table 2.12 in addition to the data in Table 2.1. The FOR of 4% is used in the adequacy study for the ATCO diesel generating units. The system PLCC at LOLE criteria of 2 hours per year and 0.1 days per year are shown in Table 2.13. The system LOLE and LOEE for a range of peak loads are shown in Table 2.14 considering two different FOR for the natural gas units in Whitehorse, i.e. 4% and 15%.

Table 2.12: ATCO/YECL Generating Unit Data Included in the Study

| Unit ID    | MCR (kW) |
|------------|----------|
| CD1        | 1280     |
| TD1        | 1200     |
| RD1        | 800      |
| HD1        | 1400     |
| Pelly G1   | 220      |
| Pelly G2   | 480      |
| Pelly G3   | 240      |
| Stewart G1 | 120      |

Table 2.13: System PLCC When ATCO Generating Units are Included in the Evaluation

| LOLE<br>Criterion | PLCC (MW)  |           |
|-------------------|------------|-----------|
|                   | NG FOR=15% | NG FOR=4% |
| 2.0 h/yr          | 105.1858   | 106.8131  |
| 0.1 d/yr          | 100.0501   | 101.3319  |

Table 2.14: Task 1 LOLE and LOEE Results Including the ATCO Generating Units

| Peak Load<br>(MW) | LOLE (h/yr) |           | LOEE (MWh/yr) |            |
|-------------------|-------------|-----------|---------------|------------|
|                   | NG FOR=15%  | NG FOR=4% | NG FOR=15%    | NG FOR=4%  |
| 78                | 0.0002      | 0.0001    | 0.300         | 0.076      |
| 80                | 0.0004      | 0.0002    | 0.858         | 0.262      |
| 82.06             | 0.0011      | 0.0005    | 2.283         | 0.818      |
| 84                | 0.0023      | 0.0011    | 5.259         | 2.171      |
| 86                | 0.0045      | 0.0025    | 11.459        | 5.412      |
| 88                | 0.0086      | 0.0051    | 23.393        | 12.393     |
| 90                | 0.0161      | 0.0095    | 45.852        | 25.798     |
| 92                | 0.0313      | 0.0169    | 88.345        | 49.812     |
| 94                | 0.0630      | 0.0317    | 173.976       | 93.821     |
| 96                | 0.1294      | 0.0635    | 347.416       | 179.075    |
| 98                | 0.2635      | 0.1356    | 709.247       | 359.650    |
| 100               | 0.4959      | 0.2799    | 1404.438      | 736.778    |
| 102               | 0.8959      | 0.5741    | 2694.632      | 1527.906   |
| 104               | 1.4964      | 1.0209    | 4894.991      | 2998.211   |
| 106               | 2.4134      | 1.6859    | 8505.274      | 5516.752   |
| 108               | 3.8869      | 2.6182    | 14269.631     | 9487.579   |
| 110               | 6.3514      | 4.1186    | 23615.104     | 15661.521  |
| 112               | 10.8700     | 6.7181    | 39305.117     | 25506.936  |
| 114               | 18.2479     | 11.4256   | 66277.711     | 42149.414  |
| 116               | 30.8129     | 20.7405   | 111452.039    | 71426.867  |
| 118               | 49.0267     | 35.4309   | 186063.719    | 123988.352 |
| 120               | 73.6220     | 56.5360   | 299618.188    | 209177.094 |

The 8 ATCO generating units in Table 2.12 have a total generating capacity of 5.74 MW. A comparison of the PLCC results in Tables 2.11 and 2.14 shows that the increase in PLCC due to the consideration of the ATCO units is 5.69 MW at the LOLE criterion of 0.1 days per year. The increase in PLCC at the LOLE criterion of 2 hours per year is 5.94 MW. These values are calculated considering 15% FOR of natural gas units at Whitehorse. The local peak loads served by the ATCO generating units must be considered in assessing the peak load that can be carried by the system.

### 3. IMPACT OF TRANSMISSION LINE OUTAGE ON GENERATING SYSTEM ADEQUACY

This section presents reliability studies on the impacts of the forced outages of the major transmission lines on the YEC generation system adequacy. The major transmission lines linking the YEC generation plants to the bulk system load at Whitehorse is shown in Figure 3.1.

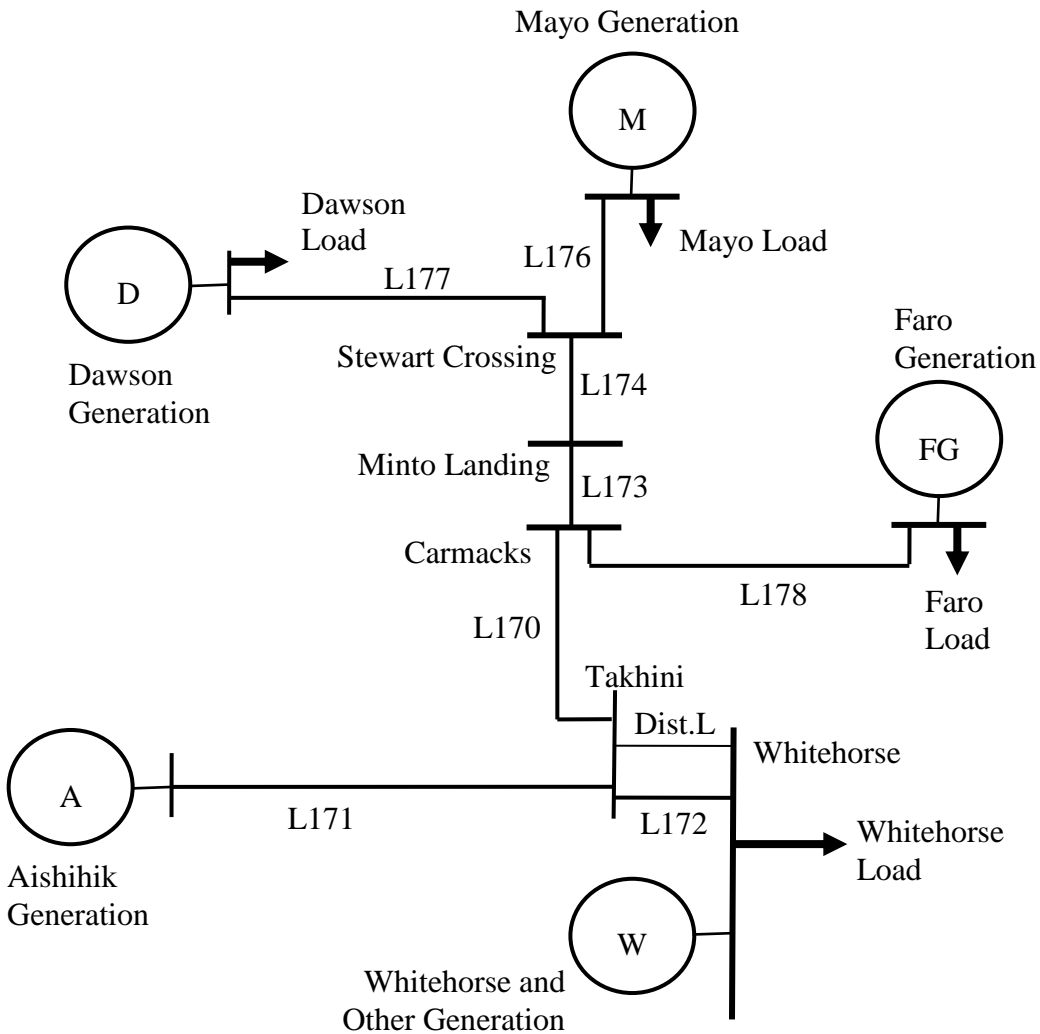

Figure 3.1: YEC Major Transmission Lines and Generation Plants

The impact of individual line segments on the ability of the YEC generation to satisfy the bulk load at the Whitehorse area is evaluated, and the resulting LOLE, LOEE and PLCC indices are calculated and compared with the base case in which the transmission system is not considered. The objective of the studies is to identify the major line segments that significantly affect the generation adequacy indices, and therefore, need to be considered in the development of the generation adequacy model of the YEC system.

### 3.1 Major Transmission Line Data

Table 3.2 shows the major YEC transmission system data that are used in the study. It should be noted that the line ID numbers have changed since the work done in the 2011 report [3].

Table 3.2: YEC Major Transmission System Data

| Line Segment                       |         | Line Length<br>(km) | Volt. Rating<br>(kV) | Structure<br>Type |
|------------------------------------|---------|---------------------|----------------------|-------------------|
| Stations                           | Line ID |                     |                      |                   |
| Dawson – Stewart Crossing          | L177    | 172                 | 69                   | wood, single pole |
| Mayo – Stewart Crossing            | L176    | 52                  | 69                   | wood, single pole |
| Stewart C. – Minto Landing         | L174    | 95                  | 138                  | wood, double pole |
| Minto Landing - Carmacks           | L173    | 71                  | 138                  | wood, double pole |
| Faro - Carmacks                    | L178    | 190                 | 138                  | wood, double pole |
| Carmacks - Takhini                 | L170    | 152                 | 138                  | wood, double pole |
| Ashihik - Takhini                  | L171    | 130                 | 138                  | wood, double pole |
| Takhini - Whitehorse               | L172    | 25                  | 138                  | wood, double pole |
| Distribution line parallel to L172 |         | 17                  | 34.5                 | wood, single pole |

All the transmission lines listed in Table 3.2 are capable of transferring the maximum power generated at the generation plants. The 34.5 kV distribution line parallel to L172 has a maximum load carrying capability of 19.6 MW, considering the overload protection setting at 20 MVA during the outage of line L172, and a power factor of 0.98.

The unavailability parameter for the 34.5 kV - 69 kV wood single pole and 138 kV wood double pole transmission lines were calculated using the 2014 CEA [6] data shown in Tables 3.3 and 3.4 respectively.

Table 3.3: CEA 2014 Transmission Line Data for < 110 kV, Wood Single-pole Structure

| Outage Type | Failure Rate<br>(failures/year) | Mean Down Time<br>(hours) | Unavailability<br>(%) |
|-------------|---------------------------------|---------------------------|-----------------------|
| Sustained   | 3.0548/100 km                   | 19.0                      | -                     |
| Transient   | 3.4406/100 km                   | -                         | -                     |
| Station     | 0.1614                          | -                         | 0.146                 |

Table 3.4: CEA 2014 Transmission Line Data for 110 – 149 kV, Wood Double-pole Structure

| Outage Type | Failure Rate<br>(failures/year) | Mean Down Time<br>(hours) | Unavailability<br>(%) |
|-------------|---------------------------------|---------------------------|-----------------------|
| Sustained   | 0.9782/100 km                   | 21.4                      | -                     |
| Transient   | 0.9087/100 km                   | -                         | -                     |
| Station     | 0.1295                          | -                         | 0.085                 |

Table 3.5 shows a sample calculation of the unavailability data for line L171 using the CEA data in Table 3.4. The sustained and transient failure rate for the 130 km lines are 1.27166 (i.e.  $0.9782 \times 130/100$ ) and 1.18131 failures per year respectively.

Table 3.5: Transmission Line L171 Unavailability Calculation

| Line and outage<br>Component | Failure rate<br>(failures/year) | Mean Down Time<br>(hours) | Unavailability |        |
|------------------------------|---------------------------------|---------------------------|----------------|--------|
|                              |                                 |                           | (hours/year)   | (%)    |
| Sustained                    | 1.27166                         | 21.4                      | 27.21352       | 0.3107 |
| Transient                    | 1.18131                         | 0                         | 0              | 0      |
| Station (one end)            | 0.1295                          | -                         | -              | 0.085  |
| Station (other end)          | 0.1295                          | -                         | -              | 0.085  |
|                              |                                 |                           | Total          | 0.4807 |

Table 3.6 shows the unavailability of all the major lines in the YEC system using the CEA 2007 [3] and CEA 2014 outage statistics for comparison.

Table 3.6: YEC Major Transmission System Unavailability Data

| Line Segment<br>(Note old line ID in brackets) | Line length<br>(km) | Unavailability (%) |               |
|--|---------------------|--------------------|---------------|
|  |                     | CEA 2007 data [3]  | CEA 2014 data |
| L177 (L174W)                                   | 172                 | 1.1827             | 1.4316        |
| L176 (L174E)                                   | 52                  | 0.5225             | 0.6365        |
| L173+L174 (L173)                               | 166                 | 0.2237             | 0.5667        |
| L178 (L170B)                                   | 190                 | 0.2476             | 0.6240        |
| L170 (L170A)                                   | 152                 | 0.2267             | 0.5332        |
| L171   | 130                 | 0.2028             | 0.4807        |
| L172   | 25                  | 0.0984             | 0.2297        |
| Distribution line parallel to L172             | 17                  | -                  | 0.4046        |

Table 3.7 and Table 3.8 show the line losses in the major transmission lines for peak load and typical load scenarios that were obtained from load flow studies done by YEC. The data has been analyzed to obtain line losses as a percentage of the line loading for the major transmission lines. The losses in the distribution line between Takhini and Whitehorse at full loading is 443 kW.

Table 3.7: YEC Major Transmission Losses at Peak Load Scenario

| Line Segment              | Length (km) | Loading (kW) | Line Losses |              |         |
|---------------------------|-------------|--------------|-------------|--------------|---------|
|                           |             |              | (kW)        | % of loading | %/100km |
| L177                      | 172         | 4958         | 99          | 2.00%        | 1.16%   |
| L176                      | 52          | 9037         | 268         | 2.97%        | 5.70%   |
| L174                      | 95          | 4597         | 41          | 0.89%        | 0.94%   |
| L173                      | 71          | 981          | 5           | 0.51%        | 0.72%   |
| L178                      | 190         | 3276         | 67          | 2.05%        | 1.08%   |
| L170                      | 152         | 1606         | 96          | 5.98%        | 3.93%   |
| L171                      | 130         | 27079        | 1185        | 4.38%        | 3.37%   |
| L172A                     | 10          | 2227         | 2           | 0.09%        | 0.90%   |
| L172B                     | 15          | 25591        | 136         | 0.53%        | 3.54%   |
| Total Losses at Peak Load |             |              | 1899        |              |         |

Table 3.8: YEC Major Transmission Losses at Typical Load Scenario

| Line Segment | Length (km) | Loading (kW) | Line Losses |              |         |
|--------------|-------------|--------------|-------------|--------------|---------|
|              |             |              | (kW)        | % of loading | %/100km |
| L177         | 172         | 2381         | 35          | 1.47%        | 0.85%   |
| L176         | 52          | 6970         | 149         | 2.14%        | 4.11%   |
| L174         | 95          | 4225         | 29          | 0.69%        | 0.72%   |
| L173         | 71          | 686          | 9           | 1.31%        | 1.85%   |
| L178         | 190         | 7641         | 31          | 0.41%        | 0.21%   |
| L170         | 152         | 4282         | 158         | 3.69%        | 2.43%   |
| L171         | 130         | 24752        | 1010        | 4.08%        | 3.14%   |
| L172A        | 10          | 2911         | 1           | 0.03%        | 0.34%   |
| L172B        | 15          | 17454        | 62          | 0.36%        | 2.37%   |

### 3.2 Local Load Data

The local loads at the major generation plants at Dawson, Mayo and Faro that occurred in the year 2015 are shown in Table 3.9. The Elsa Keno load is combined with the Mayo load considering that they will be served by Mayo generation. The Minto Mine and Pelly loads are mainly served by the respective local diesel generation, and they will have little impact on the transmission lines or the ability of the overall system to meet the main system load. The Minto Mine and Pelly generation and loads are therefore not considered in the reliability evaluation model. The Haines Junction load is primarily met by the local diesel generation, and therefore, will not impact the ability of the system to meet the bulk load at Whitehorse through the line L171. The Haines Junction load is therefore lumped with the Whitehorse load in the reliability model.

Table 3.9: Local Loads at Major Generation Plants

| Locations | Dawson | Mayo + Elsa Keno   | Faro |
|-----------|--------|--------------------|------|
| Load (MW) | 3.62   | 1.48 + 0.38 = 1.86 | 2.12 |

### 3.3 System Risk Evaluation Considering Line Outages

A conditional probability approach is used to evaluate the impact of a transmission line segment on the generating system adequacy. The generating system risk indices (i.e. LOLE and LOEE) are evaluated for the two conditions of the line segments being available and unavailable due to forced outage, and resulting risk index is calculated using Equation 3.1. The local loads isolated due to the outage of the line segment, and the corresponding line losses are subtracted from the bulk system load at the Whitehorse area when evaluating the risk indices for the condition that the line segment is on forced outage.

$$\text{LOLE} = (\text{LOLE} | L_{\text{out}}) \times U_L + (\text{LOLE} | L_{\text{in}}) \times (1 - U_L) \quad (3.1)$$

Where  $U_L$  is the unavailability of the line segment  $L$ , and  $\text{LOLE}|L_{\text{out}}$  and  $\text{LOLE}|L_{\text{in}}$  are the system LOLE given the line segment  $L$  is forced out and available respectively.

Equation 3.2 is used to calculate the system LOLE and LOEE when evaluating the impact of the parallel lines (i.e. L172 and the distribution line, DL) between Takhini and Whitehorse. Given the condition that the line L172 is out and the distribution line is available to transfer a maximum capacity of 19.6 MW to Whitehorse, the local loads at Mayo, Dawson and Faro are subtracted from the generation capacity model before passing it through the distribution line to Whitehorse. The line losses are proportionally reduced when considering this condition that has only 19.6 MW transfer capability.

$$\begin{aligned} \text{LOLE} = & (\text{LOLE} | \text{both lines out}) \times U_{L172} \cdot U_{DL} + (\text{LOLE} | L172_{\text{out}}) \times U_{L172}(1-U_{DL}) \\ & + (\text{LOLE} | DL_{\text{out}} \text{ OR no line outages}) \times (1-U_{L172}) \end{aligned} \quad (3.2)$$

Figure 3.2 shows the system LOLE as a function of the annual peak load considering the impact of the major transmission lines illustrated in Figure 3.1. The LOLE was calculated considering the impact of one transmission line at a time, except for the parallel lines between Takhini and Whitehorse indicated as L172+DL in the figure. Also, the lines L173 and L174 were combined and considered as a single line and indicated as L174+L173 in the figure. The base case results are

also shown which does not consider the impact of the transmission lines. Figure 3.3 shows a similar graph for system LOEE.

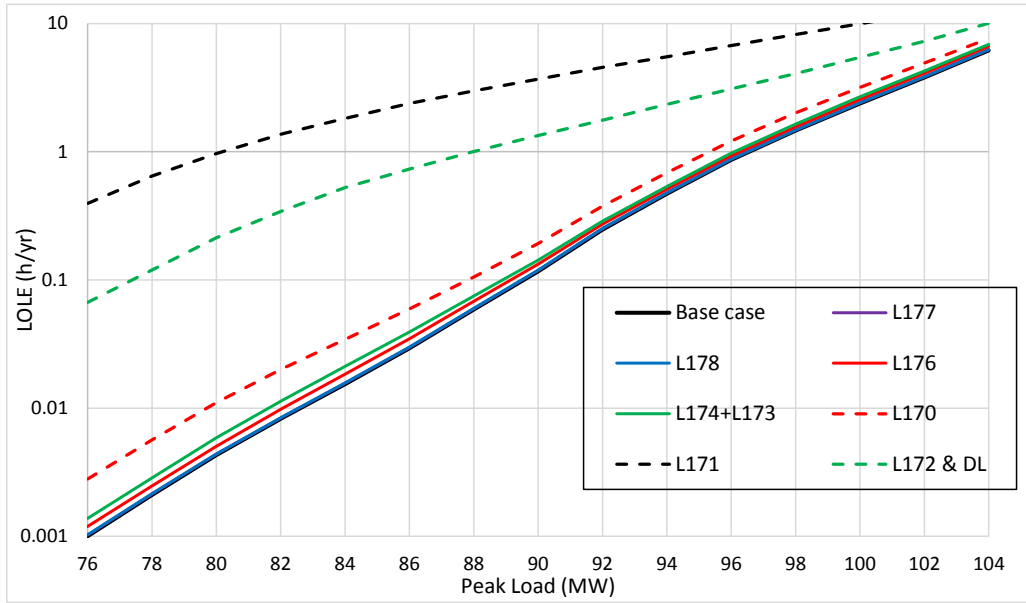

Figure 3.2: Impact of Individual Line Outage on the System LOLE

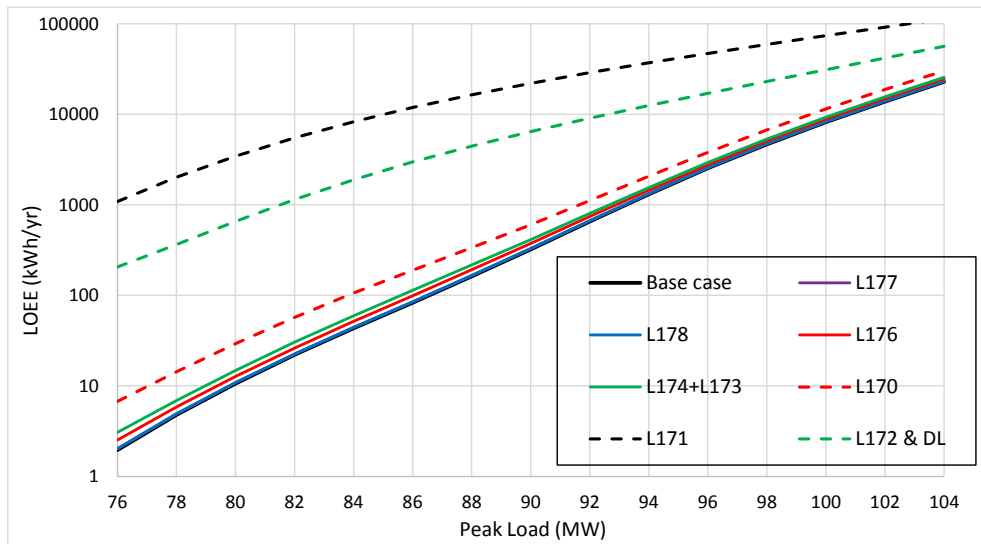

Figure 3.3: Impact of Individual Line Outage on the System LOEE

The LOLE and LOEE results for the different cases were compared with the Base Case results to assess the impacts of the different line segments on the system indices. It can be seen from Figure 3.2 that the different transmission line segments have varying impacts on the system LOLE. The lines are arranged in increasing order of their impacts on the system LOLE below:

L177 (connecting Dawson)  
L178 (connecting Faro)  
L176  
L174+L173  
L170  
L172 parallel with Distribution Line  
L171 (connecting Ashihik)

Figure 3.2 shows that the impacts of the lines L177 (connecting Dawson) and Line L178 (connecting Faro) have very little impact on the system LOLE as the results are almost the same as that obtained for the Base Case that does not consider the impact of the transmission lines. These lines therefore do not need to be considered in the generation adequacy model of the YEC system. The line L171 (connecting Ashihik) has the largest impact on the LOLE results. The impact of the parallel lines L172 and the distribution lines connecting Takhini and Whitehorse also have significant impact on the system indices. These line segments should therefore be considered in the generation adequacy model of the system. The lines L176, L174+L173 and L170 connect the Mayo hydro generation to the bulk system load at Whitehorse, and the impact of these lines increases with their proximity to Whitehorse area load. Similar observation can be noted from the LOEE results in Figure 3.3.

Redundancy in a transmission system can significantly improve its reliability, and this can be achieved by adding parallel transmission lines. It should be noted that the distribution line between Takhini and Whitehorse provides redundancy to the line L172. The load carrying capability of the distribution line, however, restricts its reliability contribution to the overall system. A study was carried out considering 2 different cases to analyze the reliability impact of the parallel lines

between Takhini and Whitehorse. Case 1 assumes that the distribution line was not installed and L172 is the only line to connect Takhini to Whitehorse. Case 2 is the actual scenario with 19.6 MW capacity of the distribution line in parallel to L172. Figure 3.4 shows the system LOLE for the 2 cases as a function of the system peak load. It should however be noted that all the other transmission lines are assumed to be 100% reliable and have no transfer restrictions in these studies. The results for the Base Case (that does not consider transmission constraints) and the case that considers only the impact of L171 alone are shown in the figure for comparison.

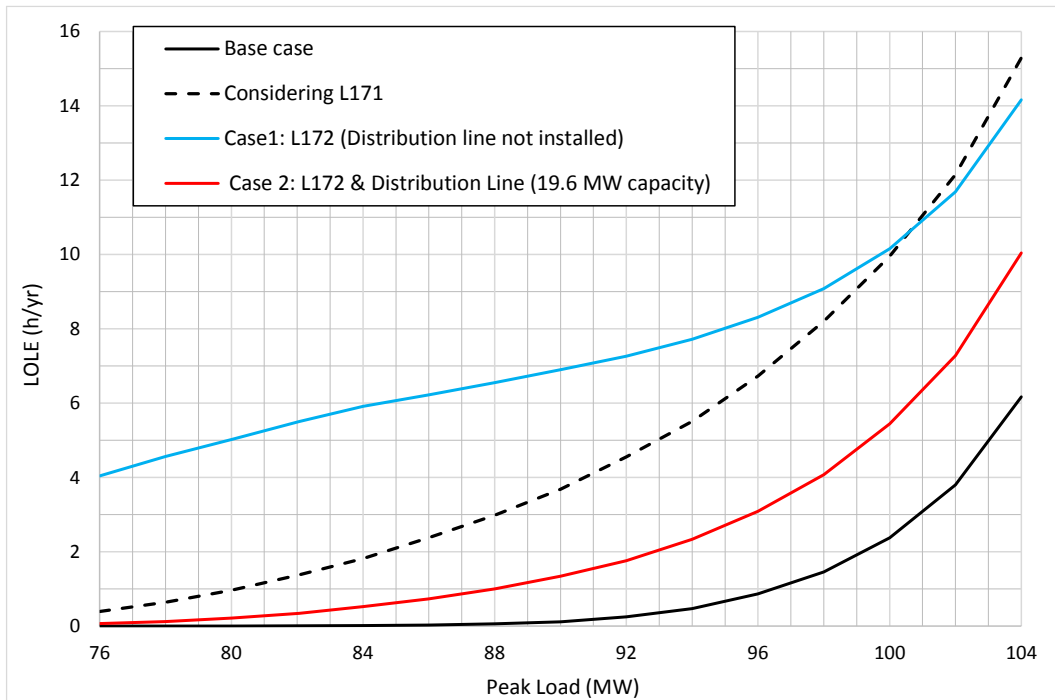

Figure 3.4: Impact of Line L172 Redundancy on the System LOLE

It can be seen from Figure 3.4 that the impact of the line L172 on the system LOLE was much greater than that of the line L171 prior to the commissioning of the distribution line between Takhini and Whitehorse. The figure shows that there has been a significant improvement in system reliability due to the distribution line between Takhini and Whitehorse despite the capacity transfer restriction of 19.6 MW. It can also be seen in the figure that the impact of the parallel lines between Takhini and Whitehorse would be negligible, and the LOLE results would be very close to the Base Case results if there was no restriction on the transfer capability of the distribution lines.

## **4. DEVELOPMENT OF GENERATING SYSTEM ADEQUACY MODEL CONSIDERING MAJOR DELIVERY CONSTRAINTS**

This section presents the development of a generating system adequacy model for the YEC considering the capacity delivery constraints imposed by the major transmission lines. The results of the generation system adequacy impacts of the individual transmission lines presented in Section 3 were analyzed to develop five different models for YEC generation adequacy evaluation. The details of the five models are described in following sub-sections.

This section illustrates results from reliability studies conducted using the different adequacy models, and presents comparative analysis to determine an appropriate generation adequacy model for the YEC electric power system.

### **4.1 Analysis of Alternate Generation Adequacy Models**

The following five different models were developed for the YEC generation adequacy evaluation based on the analysis of the results presented in Section 3. The order of the five models listed below is arranged such that the amount of input data requirements and evaluation complexity increases from Items 1 to 5 in the list.

1. Basic Generation Adequacy Model
2. WAFSREL Model
3. Extended WAFSREL Model
4. Hydro Plants Interconnection Model
5. Generation-Transmission Model

The first model or the Basic Generation Adequacy Model only considers the ability of the overall system generating capacity to meet the system load, and does not consider the transmission system. The analyses in Section 2 were done using this model. This model is shown in Figure 4.1.

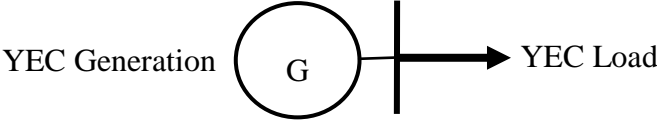

Figure 4.1: Basic Generation Adequacy Model

The LOLE and LOEE results shown in Figures 3.2 and 3.3 from comparative studies of the transmission line impacts on system adequacy clearly shows that the line L171 has the largest impact on these indices. The second model, i.e. the WAFSREL Model, considers the line L171 in the adequacy model, and is shown in Figure 4.2. The WAFSREL program [2] was developed based on this model which considers the ability of the Ashihik hydro generation capacity and its delivery through line L171 to the YEC system. The generation capacity at Whitehorse, Faro, Mayo and Dawson are also considered but their delivery constraints are not considered in this model.

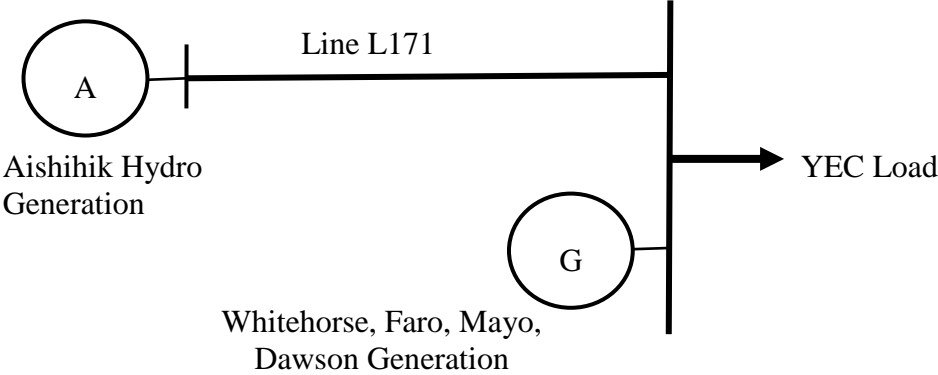

Figure 4.2: WAFSREL Model

The comparative LOLE and LOEE results in Figures 3.2 and 3.3 show that the parallel lines between Takhini and Whitehorse have the second largest impact on the adequacy indices after the line L171. The third model, i.e. the Extended WAFSREL Model shown in Figure 4.3 includes the line L171 and the parallel lines between Takhini and Whitehorse in the adequacy model. The delivery constraints of the Whitehorse, Faro, Mayo and Dawson generation are not considered in this model.

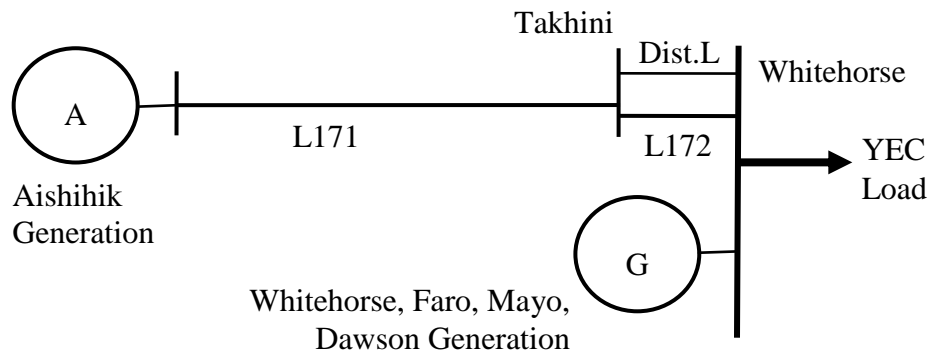

Figure 4.3: Extended WAFSREL Model

The comparative results in Figures 3.2 and 3.3 show that the transmission lines L176, L174, L173 and L170 delivering the Mayo hydro generation to the YEC system load have reasonable impact on the system LOLE and LOEE. The fourth model, i.e. the Hydro Plants Interconnection Model, considers the delivery constraints on the hydro generation from Aishihik and Mayo to serving the YEC system load, and is shown in Figure 4.4. The transmission lines L171, L176, L174, L173, L170, and the parallel lines (L172 and the distribution line between Takhini and Whitehorse) that are responsible for delivering generating capacity from Ashihik and Mayo hydro plants are considered in this model. The delivery constraints of diesel generation at Faro, Mayo and Dawson are not considered in this model. The assumption is that the diesel generation mainly meet their own local loads and have very little impact on their delivery to the rest of the YEC system.

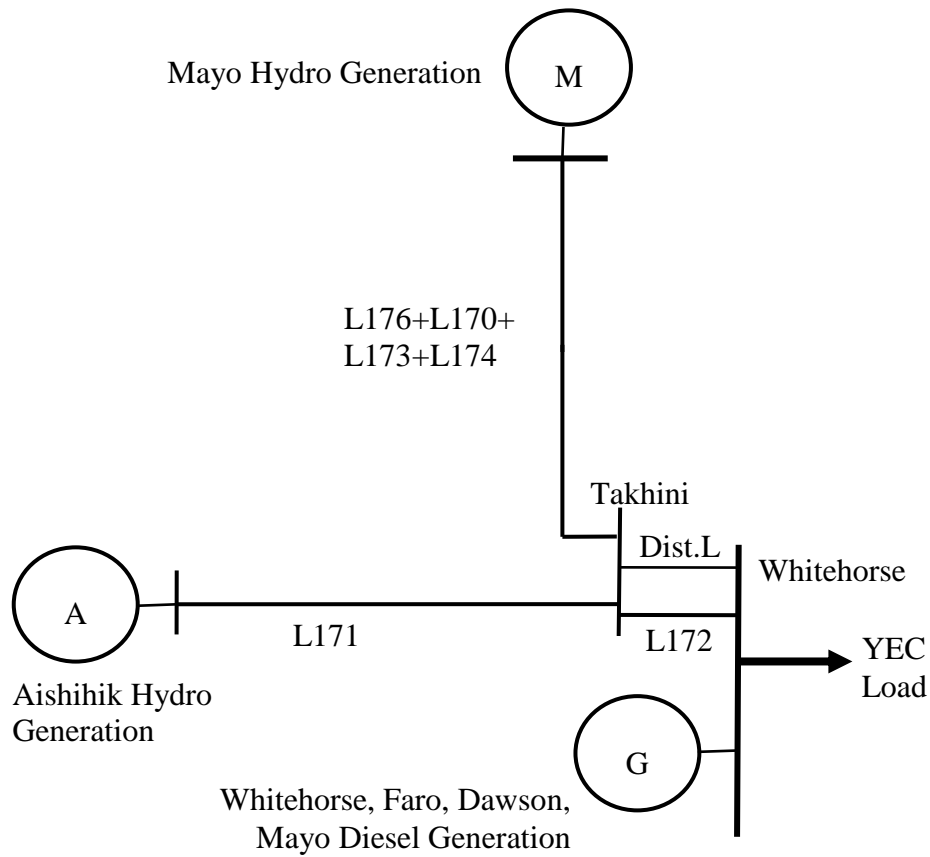

Figure 4.4: Hydro Plants Interconnection Model

The fifth model, or the Generation-Transmission Model considers the transmission constraints of the hydro plants in Ashihik and Mayo, and the diesel plants in Faro, Dawson and Mayo in serving the main system load at Whitehorse after satisfying their respective local loads at Faro, Mayo and Dawson. This model is shown in Figure 4.5.

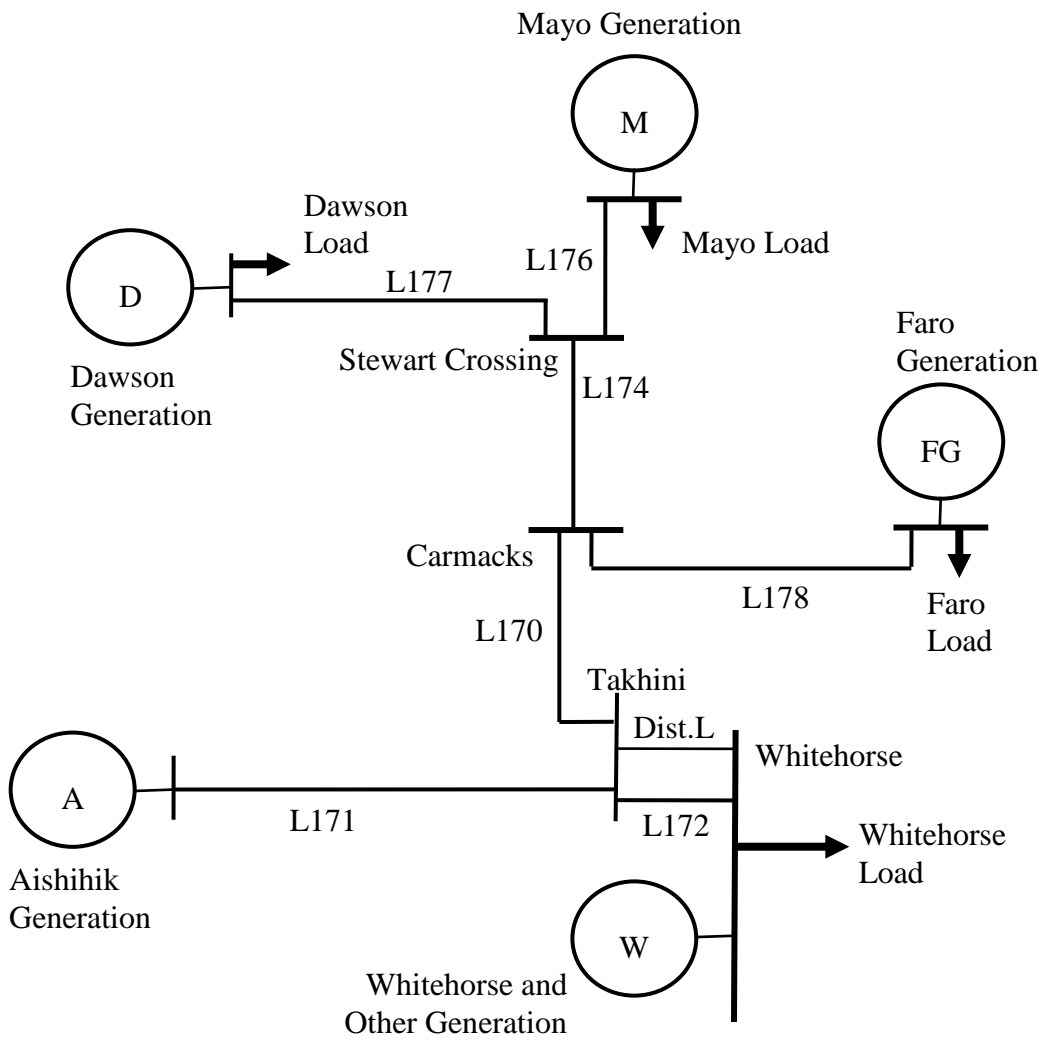

Figure 4.5: Generation-Transmission Model

## 4.2 Adequacy Evaluation Results from Alternate Models

The five adequacy models described in the previous sub-section are analyzed using generating unit data provided in Table 2.1 and the forced outage data shown in the last column of Table 2.4. The studies presented in Section 2 clearly show that the reliability indices calculated for the winter period were practically the same as those calculated for the entire year, since the summer indices were insignificant relative to the annual indices. The 5 months between the months of November and March were considered in the winter period. The hydro plant capacity limited by the winter water conditions as shown in the 6<sup>th</sup> column of Table 2.1 are used in the evaluation. A detailed analysis of the YEC load data for the past five years presented in Section 2 shows that the 2015 load model can be used instead of the average load model in adequacy studies. The 2015 winter LDC used as the load model in the following studies is shown in Figure 2.6 and Figure 2.9.

An evaluation of the YEC generation adequacy was first conducted using Model 1, the Basic Generation Adequacy Model. All the generating units listed in Table 2.4 were combined and convolved together to create the overall system generation model. The load model includes the local loads and the line losses. The system LOLE and LOEE were calculated for a range of peak loads. The results are shown in Table 4.1. It can be noted that the LOLE is 0.0084 hours per year at the system peak load of 82.06 MW. The peak load carrying capability (PLCC) is found to be 99.25 MW at the LOLE criterion of 2 hours per year when the system is represented by a basic generation adequacy model.

Table 4.1: LOLE and LOEE Results Using Model 1, the Basic Generation Adequacy Model

| Peak Load (MW) | LOLE (h/yr) | LOEE (MWh/yr) |
|----------------|-------------|---------------|
| 76.00          | 0.001       | 0.0020        |
| 78.00          | 0.0021      | 0.0048        |
| 80.00          | 0.0043      | 0.0106        |
| 82.06          | 0.0084      | 0.0225        |
| 84.00          | 0.0154      | 0.0435        |
| 86.00          | 0.0292      | 0.0833        |
| 88.00          | 0.0587      | 0.1625        |
| 90.00          | 0.1165      | 0.3217        |
| 92.00          | 0.2475      | 0.6541        |
| 94.00          | 0.4702      | 1.3070        |
| 96.00          | 0.8643      | 2.5327        |
| 98.00          | 1.4583      | 4.6678        |
| 100.00         | 2.3792      | 8.2089        |
| 102.00         | 3.797       | 13.8402       |
| 104.00         | 6.1686      | 22.9164       |
| 106.00         | 10.4473     | 37.8679       |
| 108.00         | 17.5478     | 63.6995       |
| 110.00         | 29.6536     | 106.8037      |
| 112.00         | 48.2345     | 179.4020      |
| 114.00         | 73.3794     | 291.5454      |
| 116.00         | 106.3985    | 457.0664      |

The evaluation method for Model 2, or the WAFSREL model consists of developing a winter capacity model for the Aishihik hydro plant, moving the capacity model through the transmission line L171 considering the line unavailability, and creating a tie-line constrained capacity model for the Aishihik hydro plant shown in Table 4.2. The transmission line unavailability data shown in the last column of Table 3.6 is used to incorporate the unavailability of the line L171 in this model.

Table 4.2: Tie-line (L171) Constrained Aishihik Hydro Capacity Model

| Capacity (MW) | Probability |
|---------------|-------------|
| 37            | 0.96563477  |
| 30            | 0.00975389  |
| 22            | 0.01950777  |
| 15            | 0.00019705  |
| 7             | 0.00009852  |
| 0             | 0.00480800  |

The model in Table 4.2 is then combined with the generation model that includes Whitehorse, Faro, Mayo and Dawson generation as shown in the model diagram of Figure 4.2. The overall generation system is then convolved with the winter load model to obtain the system LOLE and LOEE indices. The load model includes the local loads and the line losses. The results are shown in Table 4.3. It can be noted that the LOLE is 1.6131 hours per year at the system peak load of 82.06 MW when the system is represented by the WAFREL model, and the PLCC is 83.60 MW at the LOLE criterion of 2 hours per year.

Table 4.3: LOLE and LOEE Results Using Model 2, the WAFSREL Model

| Peak Load (MW) | LOLE (h/yr) | LOEE (MWh/yr) |
|----------------|-------------|---------------|
| 76.00          | 0.5183      | 1.5429        |
| 78.00          | 0.8136      | 2.7522        |
| 80.00          | 1.1894      | 4.5467        |
| 82.06          | 1.6131      | 7.1156        |
| 84.00          | 2.1179      | 10.2818       |
| 86.00          | 2.6931      | 14.4412       |
| 88.00          | 3.3093      | 19.5618       |
| 90.00          | 4.0615      | 25.7731       |
| 92.00          | 4.9137      | 33.2534       |
| 94.00          | 5.9141      | 42.1817       |
| 96.00          | 7.1566      | 52.9000       |
| 98.00          | 8.5885      | 65.7743       |
| 100.00         | 10.3129     | 81.1949       |
| 102.00         | 12.4845     | 99.7989       |
| 104.00         | 15.5179     | 122.8235      |
| 106.00         | 20.4168     | 152.6036      |
| 108.00         | 28.116      | 194.0624      |
| 110.00         | 40.7508     | 253.4741      |
| 112.00         | 59.7554     | 342.9590      |
| 114.00         | 85.2351     | 472.4052      |
| 116.00         | 118.5495    | 655.5268      |
| 118.00         | 158.5265    | 903.0183      |
| 120.00         | 204.8483    | 1224.7960     |

The third model, i.e. the Extended WAFSREL model consists of developing a winter capacity model for the Aishihik hydro plant, moving this model through the transmission line L171 to obtain the L171-constrained capacity model shown in Table 4.2. This model is then moved through the parallel lines between Takhini and Whitehorse considering their line unavailability and power transfer capability. The resulting tie-line constrained capacity model for the Aishihik hydro plant is shown in Table 4.4. The distribution line between Takhini and Whitehorse was considered to have a maximum power transfer capability of 19.6 MW. The transmission line unavailability data shown in the last column of Table 3.6 is used.

Table 4.4: Tie-line (L171, L172 and DL) Constrained Aishihik Hydro Capacity Model

| Capacity (MW) | Probability |
|---------------|-------------|
| 37            | 0.96341671  |
| 30            | 0.00973148  |
| 19.6          | 0.00227603  |
| 15            | 0.00019705  |
| 7             | 0.00009852  |
| 0             | 0.00481724  |

The capacity model in Table 4.4 is then combined with the generation model for Whitehorse, Faro, Mayo and Dawson. The generation model thus obtained is convolved with the system load model which includes the local loads and the line losses. The resulting system LOLE and LOEE indices are shown in Table 4.5. It can be seen that the LOLE is 1.6166 hours per year at the system peak load of 82.06 MW, and the PLCC is 83.58 MW at the LOLE criterion of 2 hours per year. It should be noted that the results obtained from this model are very close to that obtained using the WAFREL model.

Table 4.5: LOLE and LOEE Results Using Model 3, the Extended WAFSREL Model

| Peak Load (MW) | LOLE (h/yr) | LOEE (MWh/yr) |
|----------------|-------------|---------------|
| 76.00          | 0.5193      | 1.5459        |
| 78.00          | 0.8152      | 2.7575        |
| 80.00          | 1.1918      | 4.5556        |
| 82.06          | 1.6166      | 7.1300        |
| 84.00          | 2.1234      | 10.3037       |
| 86.00          | 2.7024      | 14.4762       |
| 88.00          | 3.3267      | 19.6199       |
| 90.00          | 4.0948      | 25.8770       |
| 92.00          | 4.9751      | 33.4433       |
| 94.00          | 6.0242      | 42.5296       |
| 96.00          | 7.3353      | 53.5122       |
| 98.00          | 8.8569      | 66.7976       |
| 100.00         | 10.689      | 82.8068       |
| 102.00         | 12.9871     | 102.2087      |
| 104.00         | 16.1685     | 126.2703      |
| 106.00         | 21.2256     | 157.3395      |
| 108.00         | 29.1113     | 200.3690      |
| 110.00         | 41.9219     | 261.6570      |
| 112.00         | 61.0922     | 353.2863      |
| 114.00         | 86.7837     | 485.1655      |
| 116.00         | 120.2845    | 670.9936      |

The evaluation method of model 4, i.e. the Hydro Plants Interconnection Model, considers the delivery constraints on the hydro generation from Aishihik and Mayo to serving the YEC system load as shown in Figure 4.4. The approach is to develop a winter constrained generation model for the Mayo hydro plants and then move the developed model through the transmission lines L176, L174, L173 and L170 to the Takhini station. The line-constrained Mayo hydro capacity model is shown in Table 4.6.

Table 4.6: Tie-line (L176, L174, L173 and L170) Constrained Mayo Hydro Capacity Model

| Capacity (MW) | Probability  |
|---------------|--------------|
| 0             | 0.0172343061 |
| 2550          | 0.0000019459 |
| 5000          | 0.0000019459 |
| 5100          | 0.0000963209 |
| 7550          | 0.0003852835 |
| 9000          | 0.9822801978 |

The model in Table 4.6 is convolved with the L171- constrained Aishihik hydro capacity model in Table 4.2. The probability distribution of the resulting capacity model is shown in Figure 4.6. The left graph shows the entire probability distribution, whereas, the right graph excludes the maximum capacity state of 46 MW which has a probability of 94.8524%. The spikes in the right graph show the capacity and corresponding probability resulting from first order contingencies.

The combined model is further moved through parallel lines (L172 and the distribution line between Takhini and Whitehorse) to the Whitehorse load point. The probability distribution of the capacity model, thus obtained, is shown in Figure 4.7. It can be seen that the probability of getting the maximum capacity state of 46 MW is 94.6345%. A comparison between the right plots of Figure 4.6 and 4.7 shows that there is a new spike in Figure 4.7 due to the 19.6 MW capacity limit of the distribution line between Takhini and Whitehorse. This model is then combined with Whitehorse, Faro, Dawson, and Mayo diesel generation to get the overall generation model, which is convolved with the winter load model at Whitehorse that includes the line losses and the local loads. The results for the system LOLE and LOEE for a range of peak loads are shown in Table 4.7.

It can be seen that the LOLE is 1.7603 hours per year at the system peak load of 82.06 MW, and the PLCC is 82.94 MW at the LOLE criterion of 2 hours per year. The results obtained from this model provide slightly pessimistic results when compared to the WAFREL or the extended WAFSREL models. Although the YEC generation system is presently adequate based on the WAFREL, extended-WAFSREL or the Hydro Plants Interconnection Model, a capacity expansion should be considered if load growth is expected in the near future.

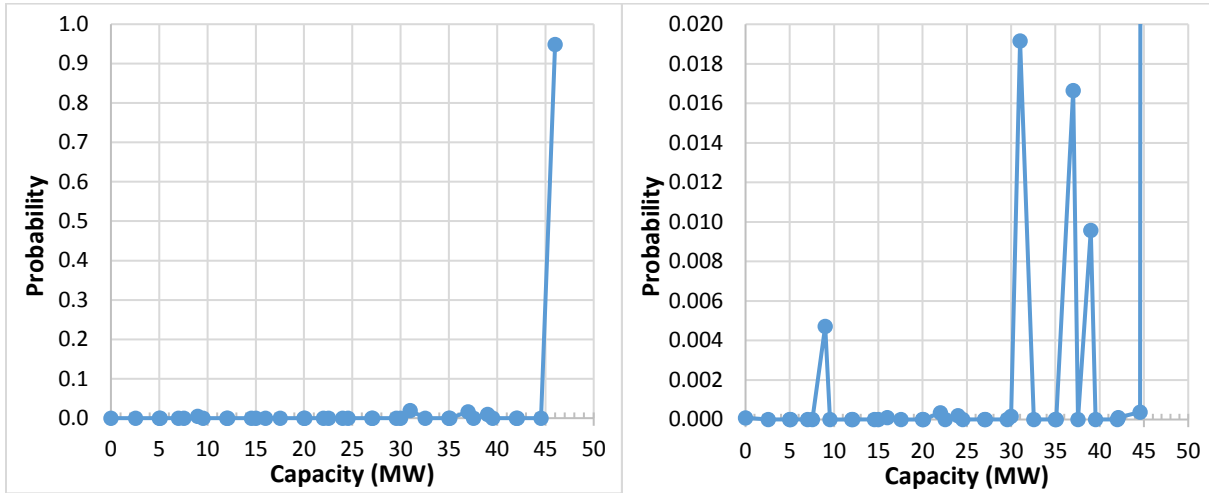

Figure 4.6: Line-Constrained Aishihik and Mayo Capacity Model at Takhini  
 (Left: entire distribution, Right: excluding maximum capacity state)

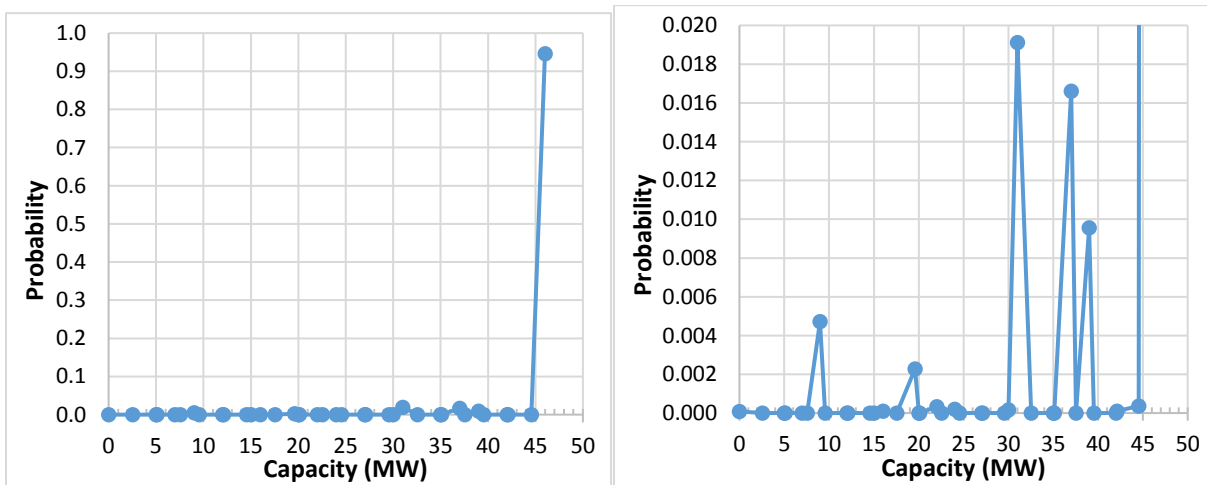

Figure 4.7: Line-Constrained Aishihik and Mayo Capacity Model at Whitehorse  
 (Left: entire distribution, Right: excluding maximum capacity state)

Table 4.7: LOLE and LOEE Results Using Model 4, the Hydro Plants Interconnection Model

| Peak Load (MW) | LOLE (h/yr) | LOEE (MWh/yr) |
|----------------|-------------|---------------|
| 76.00          | 0.574       | 1.8270        |
| 78.00          | 0.8869      | 3.1440        |
| 80.00          | 1.2901      | 5.0835        |
| 82.06          | 1.7603      | 7.8681        |
| 84.00          | 2.3347      | 11.3352       |
| 86.00          | 3.0139      | 15.9654       |
| 88.00          | 3.7775      | 21.7741       |
| 90.00          | 4.6896      | 28.9422       |
| 92.00          | 5.7444      | 37.6978       |
| 94.00          | 6.9891      | 48.2821       |
| 96.00          | 8.5144      | 61.0756       |
| 98.00          | 10.3303     | 76.6043       |
| 100.00         | 12.4881     | 95.3899       |
| 102.00         | 15.2863     | 118.2471      |
| 104.00         | 19.0767     | 146.7254      |
| 106.00         | 24.8661     | 183.3830      |
| 108.00         | 33.6123     | 233.2990      |
| 110.00         | 47.2875     | 302.8763      |
| 112.00         | 67.3836     | 404.2252      |
| 114.00         | 93.7284     | 547.1602      |
| 116.00         | 128.022     | 745.2783      |

The fifth model, or the Generation-Transmission Model considers the transmission constraints of the hydro plants in Ashihik and Mayo, and the diesel plants in Faro, Dawson and Mayo in serving the main system load at Whitehorse after satisfying their respective local loads at Faro, Mayo and Dawson. The capacity reserve models are first created for Faro, Mayo and Dawson by subtracting the respective loads from the generation models developed for these generating plants. The YEC

data indicates that the system peak load does not coincide with the peak loads at the Faro, Mayo or Dawson areas. The evaluation therefore does not consider the correlation of the loads at these locations with the system peak load, and the load model is represented by the average load at these locations when developing the reserve capacity models. The local peak load data shown in Table 3.9 was used in the evaluation, and the system winter load factor was considered to obtain the average load.

The reserve capacity models developed for the Dawson and Mayo sites are moved through the respective transmission lines L177 and L176 to Stewart Crossing. The resulting capacity model at Stewart Crossing incorporates the line losses and unavailability of the lines L176 and L177. The line losses at the different generation capacity levels in the multi-state capacity model are estimated using the line losses per unit loading data provided in Table 3.7. The unavailability data is provided in the last column of Table 3.6. The capacity model thus obtained at Stewart Crossing is then similarly moved through lines L174+L173 to Carmacks, and the capacity model is modified by incorporating the line losses and unavailability data of the line L174 and L173. This model is then combined with the modified reserve capacity model from Faro through the line L178. This evaluation procedure can be visualized by referring to the model diagram in Figure 4.5. The combined capacity model developed at Carmacks is then moved through line L170 to Takhini, and combined with the L171-constrained Aishihik generation model shown in Table 4.2. The resulting capacity model is further moved through the parallel lines (L172 and the distribution line between Takhini and Whitehorse) and combined with the Whitehorse generation model to create the overall system generation model. This system generation model is convolved with winter load model at Whitehorse that excludes the transmission line losses and the local loads at Faro, Mayo and Dawson. The system risk indices for this model are shown in the Table 4.8. The system PLCC is 82.54 MW.

Table 4.8: LOLE and LOEE Results Using Model 5, the Generation-Transmission Model

| Peak Load (MW) |             |            |        | LOLE<br>(h/yr) | LOEE<br>(MWh/yr) |
|----------------|-------------|------------|--------|----------------|------------------|
| Local          | Line Losses | Whitehorse | Total  |                |                  |
| 6.96           | 1.91        | 67.13      | 76.00  | 0.5614         | 1.8022           |
| 7.14           | 1.96        | 68.89      | 78.00  | 0.8688         | 2.9196           |
| 7.33           | 2.01        | 70.66      | 80.00  | 1.2817         | 4.6012           |
| 7.51           | 2.07        | 72.48      | 82.06  | 1.8137         | 7.0902           |
| 7.69           | 2.12        | 74.19      | 84.00  | 2.3964         | 10.2603          |
| 7.87           | 2.17        | 75.96      | 86.00  | 3.1316         | 14.5108          |
| 8.06           | 2.22        | 77.73      | 88.00  | 3.964          | 19.8972          |
| 8.24           | 2.27        | 79.49      | 90.00  | 4.8885         | 26.5327          |
| 8.42           | 2.32        | 81.26      | 92.00  | 5.9701         | 34.6093          |
| 8.61           | 2.37        | 83.03      | 94.00  | 7.1629         | 44.262           |
| 8.79           | 2.42        | 84.79      | 96.00  | 8.5875         | 55.7602          |
| 8.97           | 2.47        | 86.56      | 98.00  | 10.2407        | 69.4049          |
| 9.16           | 2.52        | 88.32      | 100.00 | 12.231         | 85.6582          |
| 9.34           | 2.57        | 90.09      | 102.00 | 14.542         | 104.9272         |
| 9.52           | 2.62        | 91.86      | 104.00 | 17.2417        | 127.826          |
| 9.71           | 2.67        | 93.62      | 106.00 | 20.6084        | 155.1726         |
| 9.89           | 2.72        | 95.39      | 108.00 | 24.969         | 188.2346         |
| 10.07          | 2.77        | 97.16      | 110.00 | 31.4755        | 229.46           |
| 10.26          | 2.82        | 98.92      | 112.00 | 40.7816        | 283.7845         |
| 10.44          | 2.87        | 100.69     | 114.00 | 53.5562        | 355.3313         |
| 10.62          | 2.92        | 102.46     | 116.00 | 73.3625        | 453.0799         |

### 4.3 Comparative Analysis of Alternate Models

Table 4.9 shows the system PLCC and Figures 4.8 and 4.9 show the LOLE and LOEE for the different alternate models for comparison. The PLCC is evaluated at the LOLE criterion of 2 hour per year.

Table 4.9: System PLCC for the Different Adequacy Models

| Adequacy Model                     | PLCC (MW) at LOLE = 2 h/yr |
|------------------------------------|----------------------------|
| Basic Generation Adequacy Model    | 99.25                      |
| WAFSREL Model                      | 83.60                      |
| Extended WAFSREL Model             | 83.58                      |
| Hydro Plants Interconnection Model | 82.94                      |
| Generation-Transmission Model      | 82.54                      |

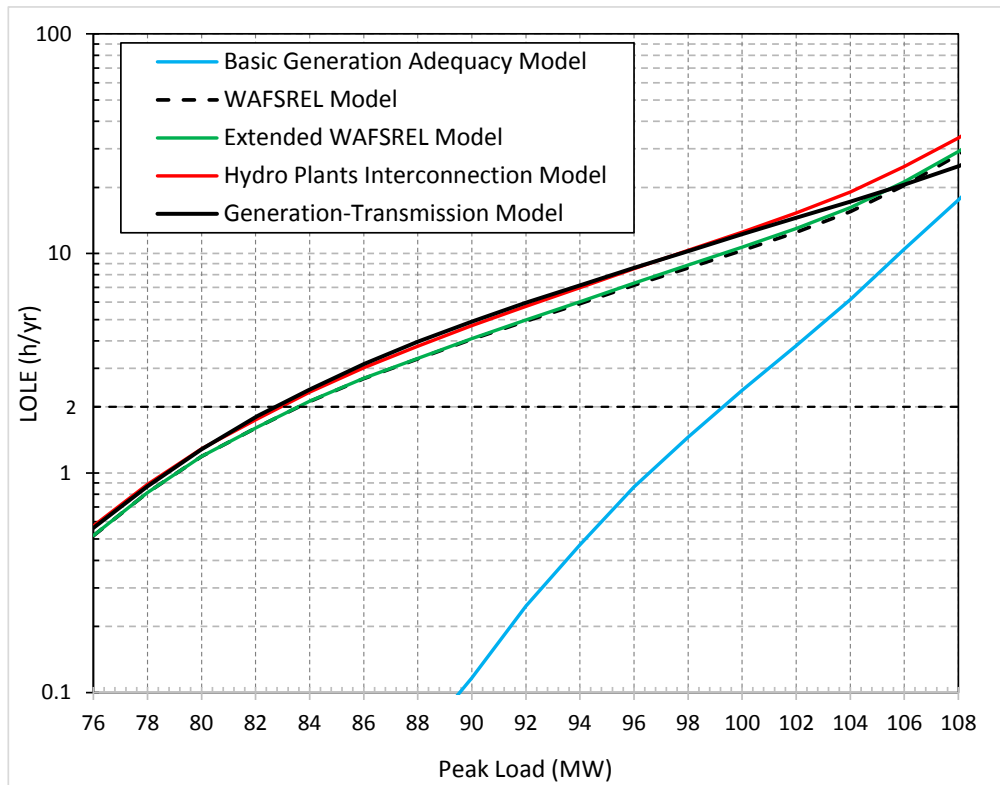

Figure 4.8: System LOLE for the Different Adequacy Models

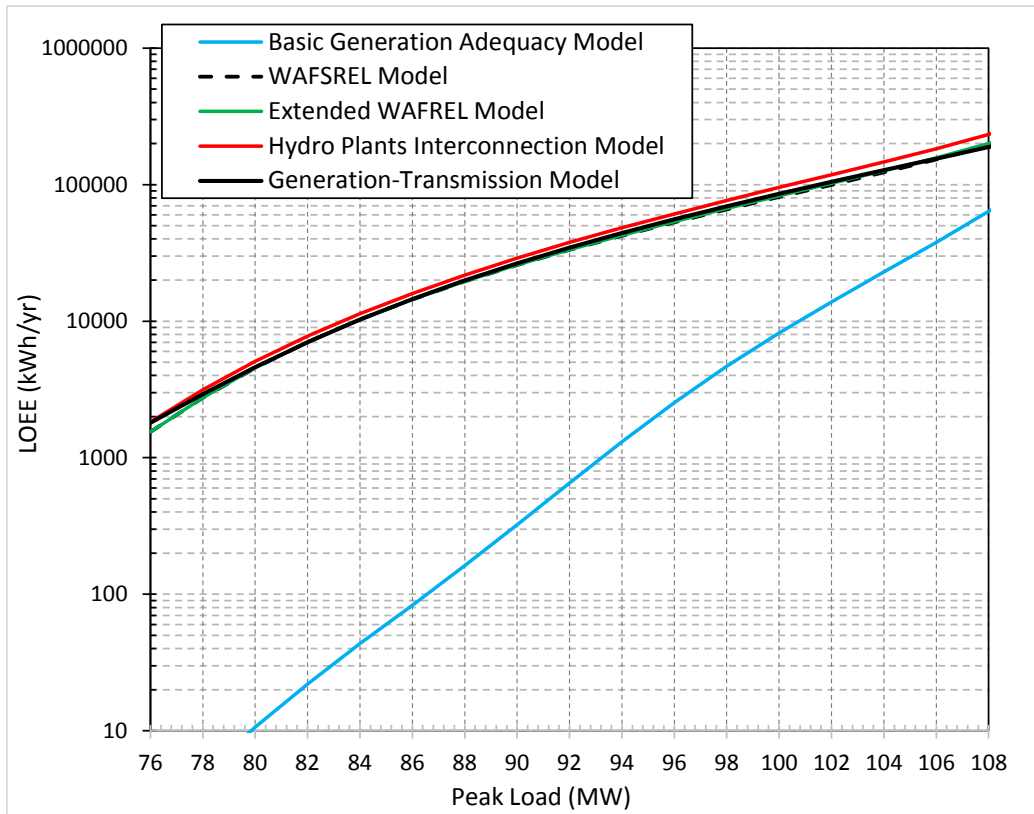

Figure 4.9: System LOEE for the Different Adequacy Models

A comparison of the LOLE results in Figure 4.8 indicates that the “Basic Generation Adequacy Model” that does not consider transmission system provides highly optimistic results. There is insignificant difference in the LOLE and PLCC results obtained from the “WAFSREL” and the “Extended WAFREL” models. The results from these two models are slightly more optimistic than that obtained from the “Hydro Plants Interconnection” and the “Generation-Transmission” models. The LOLE and PLCC results obtained from the “Hydro Plants Interconnection” and the “Generation-Transmission” models are very close for all practical purposes. It should be noted that the results become more pessimistic as the evaluation model includes more transmission system.

A composite generation and transmission system reliability evaluation, also known as HLII (Hierarchy Level II) study [4], was also carried out on the YEC electric system incorporating the locational impacts of the generation plants, transmission lines and load points considering the network in Fig. 4.5. A contingency enumeration approach [4] was applied to determine the

probabilities of energy curtailment at the different load points, and the transmission losses were evaluated based on the power flow. Since the Expected Energy Not Supplied (EENS) or the LOEE is the most widely used HLII reliability index, this index was calculated for each load point and aggregated to obtain the system EENS. Fig. 4.10 compares the EENS obtained from the HLII evaluation with the LOEE values obtained using the 5 different generation adequacy (or HLI) models.

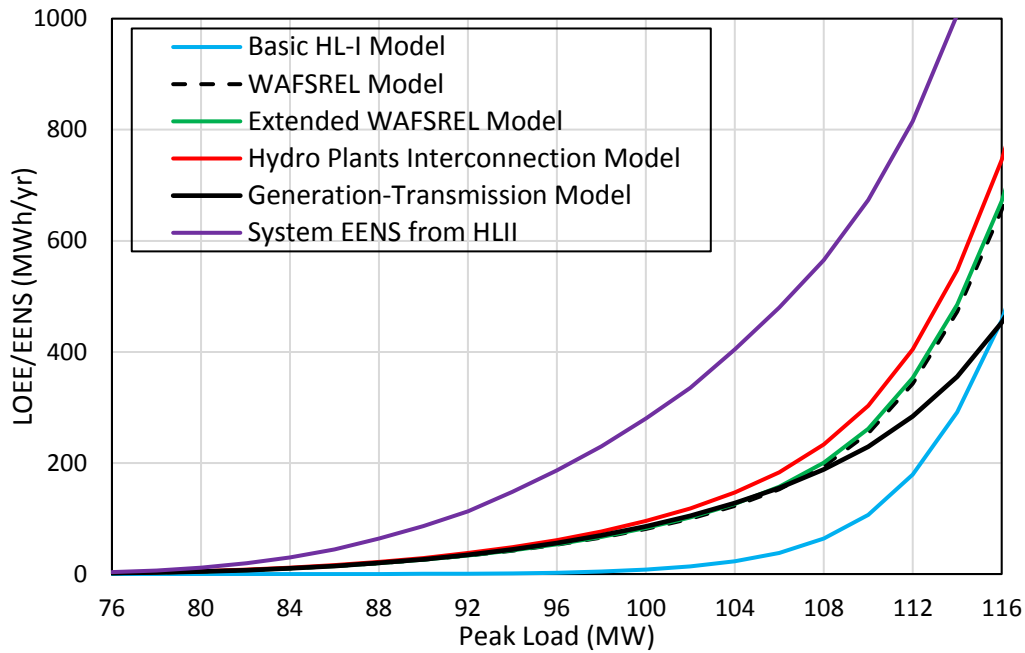

Figure 4.10: System LOEE/EENS Obtained from HLII and the 5 Different HLI Adequacy Models

As noted earlier, the order of the five generation adequacy or HLI models described above are arranged such that the amount of input data requirements and evaluation complexity increases from Models 1 to 5 in the list. In this order, the models also deviate further away from a basic generation capacity adequacy model towards a composite generation and transmission adequacy or HLII model. It should be noted that the objective of reliability study in generation capacity planning is to assess the generation system’s ability to meet the system demand over the planning horizon considering only the major capacity delivery constraints, and not the entire transmission system. It should also be noted that the capacity planning criterion of LOLE of 2 hours per year

was determined by conducting comparative studies [1] of the previous YEC firm capacity criterion using the WAFSREL model.

It can be seen from Figure 4.10 that the LOEE/EENS plots for all the models, except the Generation-Transmission Model, increase with similar slopes as the system peak load increases. The Generation-Transmission model provides highly optimistic results at high peak loads since it is assumed in this model that the local generation provides support to the Whitehorse load only after satisfying their respective local loads. This results in the local load points being highly reliable and also reduced constraints on power delivery. It should be noted that the Generation-Transmission model assumes the local loads to increase in the same proportional to the system load, similar to that assumed in the HLII model. The “Generation-Transmission Model” is also more complex than the “Hydro Plants Interconnection Model”, and requires more input data, such as, losses in the individual lines at different loading levels, correlation between local loads and the load at Whitehorse, the priority of the local loads and the Whitehorse load, etc. A comparative analyses of the results from the 5 different HLI models suggest that the “Hydro Plants Interconnection Model” is a suitable generation adequacy model for the YEC system since it is relatively simple and provides the least optimistic results among the five HLI models based on LOEE, and comparable results to the “Generation-Transmission Model” at reasonable peak load levels.

## **5. CASE STUDIES CONSIDERING POTENTIAL SYSTEM SCENARIOS**

This section presents results from different case studies that are assumed to be likely system scenarios in the future. The evaluation was carried out with the recommended generating system adequacy evaluation model, i.e. Hydro Plants Interconnection Model. It is expected that two of the existing YEC system diesel units, FD1 and WD3, will retire in the year 2021, and all of the remaining diesel units in the YEC system will retire in the year 2026. The impact of these unit retirements on the generation system adequacy has been evaluated and presented in this section. This section also presents study results with and without considering the YECL hydro and diesel generating units in the Yukon electric system adequacy. The YEC system also has four mobile diesel units with a total capacity of 435 kW. Their impact on the system adequacy is carried out in the study. It is likely that the YEC system can benefit from capacity assistance through the proposed Skagway-Whitehorse transmission line. The adequacy impact of the assistance through this interconnection is also analyzed and presented in this section. It should be noted that the existing capacity of the distribution line parallel to L172 is considered to be 19.6 MW in the studies presented in the previous sections of this report. This section also includes results from case studies carried out to analyze the impact of upgrading this line. The reliability impact of twining the line L171 is also presented.

The generation data of the YECL Fish Lake hydro units is shown in Table 5.1 with a total capacity of 1295 kW. The unit ID and MCR of YECL Diesel units are shown in Table 2.12. The total diesel capacity is 5740 kW. The total YECL capacity considered in this study is therefore 7035 kW. The unavailability of the hydro and diesel units are assumed to be the same as that of YEC units. The FOR of 4% is used in the adequacy study for the YECL diesel generating units. Table 5.2 shows the unit ID, MCR and FOR of the mobile diesel units of YEC. The FOR of 4% is used for these diesel units as well.

Table 5.1: YECL Hydro Generating Unit Data

| Unit ID      | MCR (kW) | FOR (%) |
|--------------|----------|---------|
| Fish Lake #1 | 815      | 1       |
| Fish Lake #2 | 480      | 1       |

Table 5.2: Mobile Diesel Generating Unit Data Included in the Study

| Unit ID | MCR (kW) | FOR (%) |
|---------|----------|---------|
| YM2     | 150      | 4       |
| YM3     | 125      | 4       |
| YM4     | 35       | 4       |
| YM5     | 125      | 4       |

The Skagway-Whitehorse transmission line is rated at 138 kV. The line is considered to have a length of 170 km, and mainly supported by wood double pole tower structure. The unavailability of the line is calculated to be 0.5762%. The calculation of the line unavailability is shown in Table 5.3, using the 2014 CEA [6] data shown in Table 3.4.

Table 5.3: Proposed Skagway-Whitehorse Transmission line Unavailability Calculation

| Line and outage component | Failure rate (failures/year) | Mean down time (hours) | Unavailability |        |
|---------------------------|------------------------------|------------------------|----------------|--------|
|                           |                              |                        | (hours/year)   | (%)    |
| Sustained                 | 1.66294                      | 21.4                   | 35.586916      | 0.4062 |
| Transient                 | 1.54479                      | 0                      | 0              | 0      |
| Station (one end)         | -                            | -                      | -              | 0.085  |
| Station (other end)       | -                            | -                      | -              | 0.085  |
|                           |                              |                        | Total          | 0.5762 |

The Skagway-Whitehorse Transmission line is proposed to have a load carrying capability of 25 MW. The capacity assistance to the YEC electric system through this line is modeled as an equivalent 2-state generating unit with 25 MW capacity, and a FOR of 0.6%.

## 5.1 Considering Existing Generation Facilities

An adequacy study was carried out considering all the existing generation facilities, i.e. the YEC generating units listed in Table 2.1, YECL diesel and hydro generating units listed in Table 2.12 and 5.1, and the YEC mobile generating units listed in Table 5.2. The total winter generating capacity in this case is 116.278 MW. The system LOLE and LOEE as a function of the system peak load are shown in Table 5.4. The LOLE and LOEE results are also on shown graphically in Fig. 5.1 and 5.2 respectively.

Table 5.4: LOLE and LOEE Results Obtained Considering All Existing Generation

| Peak load(MW) | LOLE(h/yr) | LOEE(MWh/yr) |
|---------------|------------|--------------|
| 76            | 0.0539     | 127.828      |
| 78            | 0.1099     | 276.769      |
| 80            | 0.2037     | 562.556      |
| 82            | 0.3580     | 1076.232     |
| 84            | 0.5783     | 1931.139     |
| 86            | 0.861      | 3235.328     |
| 88            | 1.2239     | 5110.522     |
| 90            | 1.6550     | 7678.792     |
| 92            | 2.1665     | 11043.630    |
| 94            | 2.7855     | 15356.630    |
| 96            | 3.4928     | 20784.520    |
| 98            | 4.3078     | 27450.560    |
| 100           | 5.2743     | 35577.480    |
| 102           | 6.4064     | 45410.010    |
| 104           | 7.8489     | 57343.260    |
| 106           | 9.5918     | 71917.620    |
| 108           | 11.7347    | 89728.600    |
| 110           | 14.5850    | 111758.500   |
| 112           | 18.6151    | 139684.100   |
| 114           | 24.9623    | 176714.900   |
| 116           | 34.2808    | 227841.400   |

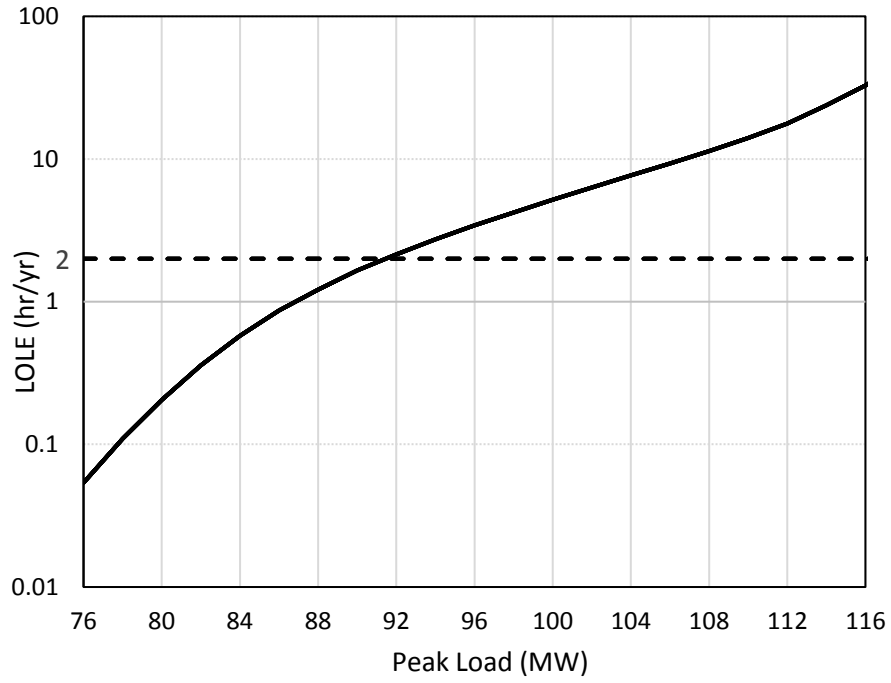

Figure 5.1: System LOLE Considering All Existing Generation

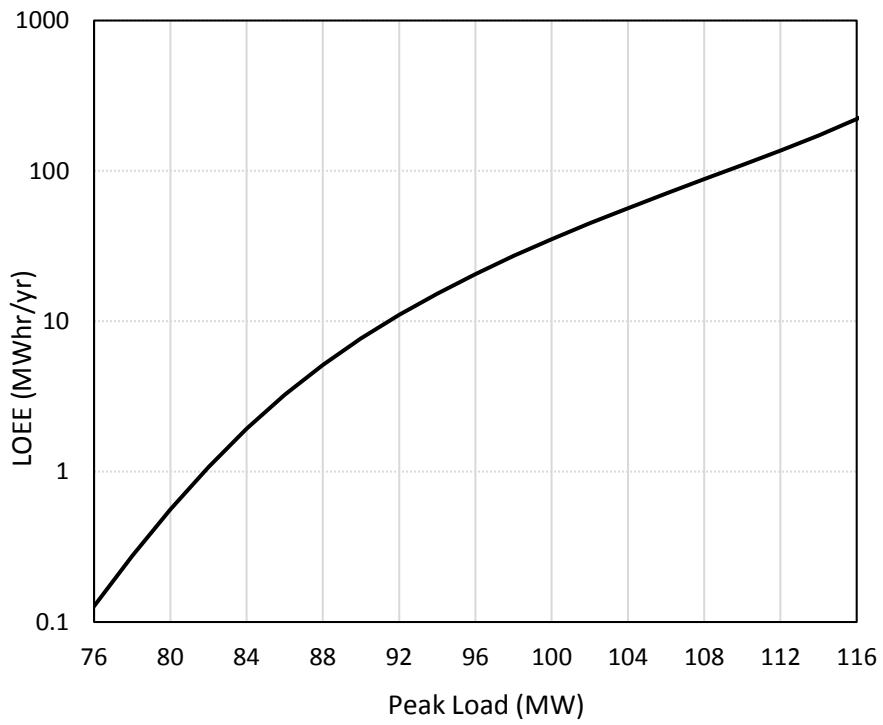

Figure 5.2: System LOEE Considering All Existing Generation

The impact of the mobile generation and the YECL generation on the overall YEC system adequacy was also analyzed. Fig. 5.3 shows the contribution of the mobile generation and the YECL generation on the system LOLE as a function of the system peak load.

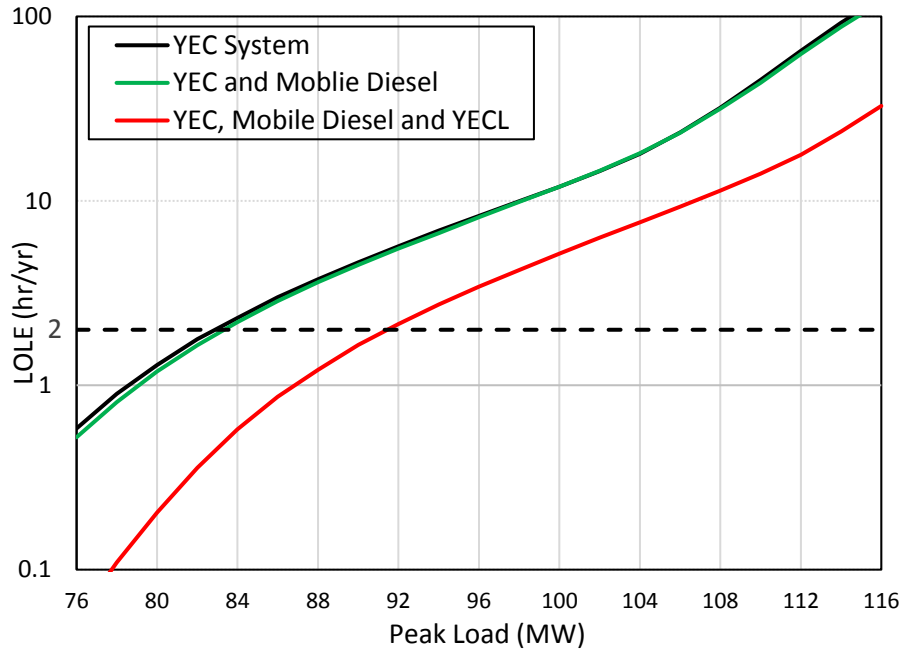

Figure 5.3: Impact of Mobile and YECL Generation on the System LOLE

The YECL and mobile generation enables the YEC electric system to carry an increased load. The peak load carrying capability of the YEC system while maintaining a reliability criterion of LOLE = 2 hours/year was evaluated, and the impact of the mobile and the YECL generation on the system PLCC is shown in Table 5.5.

Table 5.5: Impact of Mobile and YECL Generation on the System PLCC at the LOLE Criterion of 2 hours/year

| Generating Units Considered                        | PLCC (kW) |
|--|-----------|
| YEC Generation listed in Table 2.1                 | 82811.5   |
| Plus mobile units listed in Table 5.2              | 83336.7   |
| Plus YECL units listed in Table 2.12 and Table 5.1 | 91391.3   |

The YEC has improved the reliability of its electric system by adding redundancy to the line L172 with a parallel distribution line. An evaluation was done to quantify the reliability impact of the parallel line addition in terms of the increase in peak load carrying capability of the system while considering all the existing generation facilities. Table 5.6 shows the increase in PLCC (IPLCC) due to the distribution line is 7072 kW. A further upgrade of this line by increasing its load transfer capability can only increase the PLCC of the system by 342 kW.

Table 5.6: Impact of the Distribution Line Addition and its Upgrade on the System PLCC at the LOLE Criterion of 2 hours/year Considering All Existing Generation

| Study Cases   | PLCC (kW) | IPLCC (kW) |
|---|-----------|------------|
| Before addition of the distribution line            | 84319.4   | -          |
| With the line addition (19.6 MW transfer capacity)  | 91391.3   | 7071.9     |
| Upgrade the line (no transfer capacity restriction) | 91733.3   | 342        |

## 5.2 Considering Unit Retirement Scenario in the Year 2021

It is expected that two of the YEC system diesel units FD1 and WD3 will retire in the year 2021. The system PLCC at the LOLE criterion of 2 hours/year with the retirement of the two diesel units are shown in Table 5.7. The table shows the results for the following case studies:

- i. Considering only YEC generating units listed in Table 2.1
- ii. Considering YEC generation, YECL generation and the mobile generating units
- iii. Considering all the generation in Case ii and the assistance from the Skagway-Whitehorse transmission line
- iv. Considering all the generation in Case ii and the upgrade of the distribution line between Takhini and Whitehorse
- v. Considering all the generation in Case ii and twining the line L171 between Aishihik and Takhini

Table 5.7: System PLCC at LOLE criterion of 2 hours/year for different scenarios assumed for the Year 2021 after the retirement of units FD1 and WD3

| Study Cases   | PLCC (MW) |
|---|-----------|
| i. YEC generation only                                  | 73.1831   |
| ii. YEC, YECL and mobile generation                     | 81.8042   |
| iii. All generation and assistance from Skagway line    | 109.9031  |
| iv. All generation and upgrade of the distribution line | 82.0146   |
| v. All generation and twining line L171                 | 95.1002   |

### 5.3 Considering Unit Retirement Scenario in the Year 2026

It is expected that all the diesel units of within the YEC system will retire in the year 2026. The system PLCC at the LOLE criterion of 2 hours/year with the retirement of all the YEC diesel units are shown in Table 5.8. The table shows the results for the following case studies:

- i. Considering only YEC generating units listed in Table 2.1
- ii. Considering only YEC generating units and YECL units listed in Tables 2.12 and 5.2.
- iii. Considering all the generation in Case ii and the assistance from the Skagway-Whitehorse transmission line
- iv. Considering all the generation in Case ii and the upgrade of the distribution line between Takhini and Whitehorse
- v. Considering all the generation in Case ii, assistance from the Skagway-Whitehorse transmission line and the upgrade of the distribution line between Takhini and Whitehorse
- vi. Considering all the generation in Cases ii and twining the line L171 between Aishihik and Takhini
- vii. Considering all the generation in Cases ii, assistance from the Skagway-Whitehorse transmission line, and twining the line L171 between Aishihik and Takhini

Table 5.8: System PLCC at LOLE criterion of 2 hours/year for different scenarios assumed for the Year 2026 after the retirement of all YEC diesel units

| Study Cases   | PLCC<br>(MW) |
|---|--------------|
| i. YEC generation only  | 48.1696      |
| ii. YEC and YECL generation   | 56.3378      |
| iii. All generation and assistance from Skagway line                                  | 85.3039      |
| iv. All generation and upgrade of the distribution line                               | 56.3733      |
| v. All generation, assistance from Skagway line, and upgrade of the distribution line | 85.5520      |
| vi. All generation and twining line L171  | 71.2489      |

## REFERENCES

1. R. Karki and R. Billinton “WAFSREL – User’s Manual”, Yukon Energy Corporation, 2006.
2. R. Karki and R. Billinton “Reliability Evaluation of the Whitehorse-Aishihik-Faro System”, Yukon Energy Corporation, February 2005.
3. R. Karki, R. Billinton, “Analyses of Transmission Constraints on Generation Adequacy Model for Yukon Energy Corporation”, Technical Report prepared for YEC, 2011.
4. R. Billinton and R. N. Allan, “Reliability Evaluation of Power Systems – Second Edition”, Plenum Press, 1994.
5. Canadian Electricity Association – Equipment Reliability Information System, “2014 Generation Equipment Status Annual Report”.
6. Canadian Electricity Association – Equipment Reliability Information System, “2014 Annual Report, Forced Outage Performance of Transmission Equipment”.