

# Dawson LED Streetlight Pilot Project – Final Report

A Yukon Energy Corporation project to assess the performance and acceptability of LED streetlights in Dawson City, Yukon.



## Table of Contents

1. Introduction .....	3
2. Methodology.....	3
3. Results.....	4
3.1 Lumen Output .....	4
3.2 Energy Usage.....	4
3.3 Public Opinion survey .....	6
4. Human and Environmental Considerations .....	6
5. Conclusions .....	7
APPENDICES .....	8
Appendix A: RUUD Beta B LED Technical Information.....	8
Appendix B: Dawson Pilot LED Streetlight Layout .....	9
Appendix C: Public Survey Methodology, Questionnaire and Results .....	10
Appendix D: Lumen Monitoring Datasheet and Results.....	20
Appendix E: Public Advertising and Newsletters .....	25

## List of Figures

FIGURE 1. ESTIMATED ENERGY USAGE BY HPS AND LED FIXTURES – JUNE 2010 TO MAY 2011	5
--	---

## 1. Introduction

Yukon Energy Corporation (YEC) is currently leading the development of a Yukon-wide Demand Side Management (DSM) Plan with the aim of prioritizing energy conservation as a resource. As part of this development process YEC is conducting pilot projects to test the applicability of various program components.

From September 2010 to May 2011, Yukon Energy, in partnership with the Energy Solutions Centre conducted a pilot project to test light-emitting diode (LED) streetlight technology in Dawson City. This pilot project was designed to test the performance of LED technology throughout a Yukon winter and to gauge public acceptance of the lights.

A similar pilot was conducted in Whitehorse by Yukon Electrical Company Ltd (YECL), with financial support from Yukon Energy and the Energy Solutions Centre. Four types of lights from different manufacturers (RUUD Lighting, General Electric, Focus Lighting, and LED Roadway) were tested in this pilot. Findings from this pilot can be found in a separate report from YECL.

## 2. Methodology

Given the small number of streetlights being tested in Dawson City, it was decided that one brand of LED streetlight would be installed. Lights from RUUD Lighting were selected because it was the brand chosen in several Alaskan communities based on significant testing in Anchorage, Alaska several years ago. The lights were a 40 LED model with three lighting settings, allowing for more flexibility if the lights were found to be too bright or too dark during the pilot. The technical specifications on the chosen RUUD lights can be found in Appendix A. Due to concerns about light pollution, back light shields were installed to reduce glare into buildings behind the streetlights.

In consultation with the Municipal government in Dawson City and YEC operations staff, 6 LED lights were installed along Second Avenue between Albert Street and York Street. Locations can be seen in Appendix B.

Two dataloggers, measuring energy consumption, were installed on one of the LED lights and on one of the existing high pressure sodium (HPS) lights to collect comparative data on energy usage. Light meter readings, measuring the lumen output (brightness of the lights), were also taken periodically throughout the project test period.

Public involvement in the project included signage on the LED light standards, an initial newsletter describing the project and postings on the Yukon Energy website and blog. An interim household newsletter was sent out with a public opinion survey by mail to all Dawson addresses in early February. Postage paid return envelopes and one prize of a set of LED flood lights were provided as incentives to complete the survey. A discussion of the survey results can be found in section 3.3 of this report and the results of the survey can be found in Appendix C.

## 3. Results

### 3.1 Lumen Output

Light meter readings, measuring lumen output (brightness), of the lights were conducted periodically to ensure that the lights provided lighting levels that were appropriate. Meter readings were taken at a set distance of 5 m from each of the 6 LED test lights and the HPS light with a handheld light meter. The results of this monitoring can be found in Appendix D. The light meter readings were consistent throughout the test period and lumen output did not diminish during cold temperature periods or intense ice fog.

### 3.2 Energy Usage

An important component of the LED pilot project was to measure the energy usage of the LED lights in comparison with the existing HPS lights. The monitoring of energy usage for both street light types over an extended period of time enabled the quantification of potential annual energy savings.

Dataloggers were installed in October 2010 on one LED and one HPS street light. Each logger recorded outside air temperature, voltage and current data at 2-minute intervals. A strong linear relationship between the power drawn by the light fixture and the outside air temperature was derived from the data collected. More precisely, the data show a 87% and 96% correlation between both variables for HPS and LED lights, respectively. The data indicate that the power drawn by the street lights decreases as outside air temperature decreases. This observation was later confirmed by the lighting consultant Prolux (*John Campbell, pers. comm.*).

Because the data collection period lasted eight months, the linear relationship defined from the monitoring data was used to generate an energy usage profile over the entire period (June 2010 to May 2011). The calculated energy use profile is in close agreement with the monitoring data and is therefore deemed adequate for further analyses. The calculated energy usage profile of the LED light as compared to the HPS light and the resulting energy savings are presented on Figure 1 below.

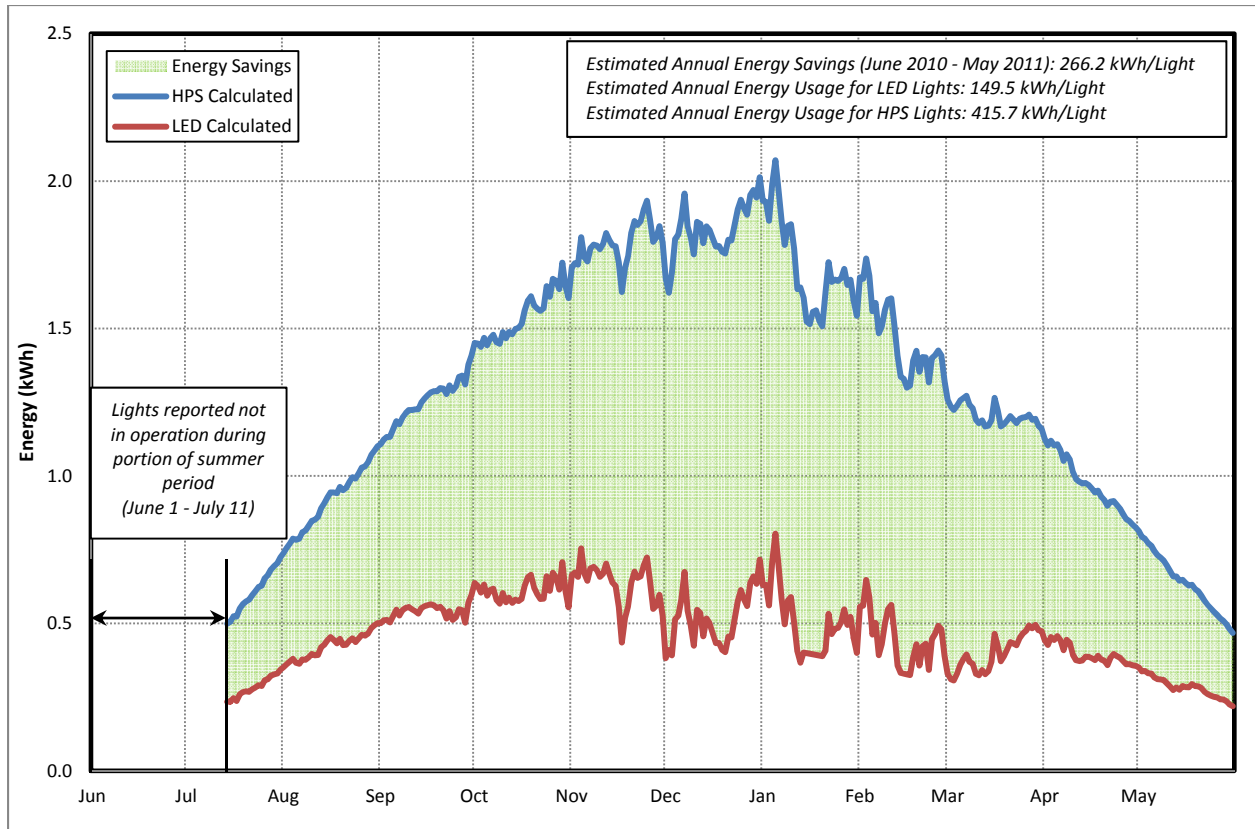

**FIGURE 1. ESTIMATED ENERGY USAGE BY HPS AND LED FIXTURES – JUNE 2010 TO MAY 2011**

The annual energy usage for the HPS fixture is estimated at 415.7 kWh/light (106 W). In comparison, the energy usage by the LED amounted to 149.5 kWh/light (38 W). Thus, the resulting energy savings that could have been achieved during the assessment period (June 2010 – May 2011) is estimated at 266.2 kWh/light, or 64%.

YEC staff reported that the street lights are not in operation during part of the summer as a result of the long daylight hours. Because monitoring data indicated they were still in operation in late May, it was assumed that the lights would not operate from early June to the solstice and for a period of equal duration after the solstice. The period when the lights are not in use should be confirmed; however it is interpreted that any incremental energy that would be required over this period is marginal (i.e., less than 5 kWh) based on outside air temperature and hours of operation data. Any energy use when streetlights are in operation as a result of extremely cloudy evenings is considered to be minimal and as such, has no significant effect on overall energy use estimates.

Several null readings were present in the dataset at times when the lights were in operation. This occurred during periods of extreme low temperatures (i.e. -40 °C). These null reading were attributed to the sensitivity of the amp probe and specifically its inability to accurately measure very low current.

This preliminary data is deemed to be acceptable for the purposes of the economic testing and light performance analysis. The considerations detailed above should be kept in mind and additional data collected to increase confidence in the estimated energy savings.

### 3.3 Public Opinion survey

A survey was given to all Dawson residents and businesses using a bulk mail-out in early February 2011. Of the 76 responses, 67 came from residents and 9 came from businesses. 87% of respondents like the LED lights and felt that they provided the right amount of light. 84% liked the colour of the lights and 89% supported switching from HPS to LED streetlights. There were some concerns about using LED's within the downtown core in Dawson due to the designation of Dawson City as a national historic site. As discussed below, Yukon Energy will work with the Heritage Advisory Committee in Dawson to manage this concern moving forward.

## 4. Human and Environmental Considerations

The following human and environmental factors were considered in choosing the type of LED lights for the pilot:

- Light pollution;
- Effects of light on human health;
- Effects of light on wildlife health, especially migrating salmon;
- Safety; and
- Hazardous substances in the bulbs.

Maintaining dark night skies and preventing light pollution is important to many Yukoners. The LED lights selected are dark sky friendly and approved by the International Dark Sky Association (IDA). It was observed that there was practically no light pollution visible from the pilot LED lights when looking onto downtown Dawson from 6<sup>th</sup> Ave (*Pers. Comm. Sheldon Sollosy*).

The Illuminating Engineering Society of North America (IESNA) has published classifications and guidelines on measuring and rating the backlight, uplight and glow (BUG) from outdoor lights. The IESNA guidelines also specify the ratings that are appropriate for a specific area. This helps to ensure that lighting is appropriate for the space and reduces light pollution and nuisance lighting, such as glare into residential homes. The lights chosen for the pilot have low BUG ratings with a backlight rating of 0, and an uplight and glare rating of 1 (ratings are done on a scale of 0-4).

IESNA has also published their position on the potential health effects of outdoor lighting in *Light and Human Health: An Overview of the Impact of Optical Radiation on Visual, Circadian, Neuroendocrine and Neurobehavioral Responses (TM-18-08)*. TM-18 indicates that exposure to optical radiation does affect human physiology and behavior with effects including melatonin suppression, elevated cortisol production, increased core temperature and by resetting the internal circadian rhythm. The positions of

the IESNA is that typical exposure to exterior lighting after sunset has not been shown to lead to cancer or other life threatening conditions. The IESNA also believes that more research into the effects needs to be completed and a better understanding of the effects of exterior lighting on health brought forward. To help reduce any potential impact exterior lighting could have on human health, reduction light pollution and light glare into homes has been incorporated into the LED lighting design

Although the relationship between light temperature and melatonin is not well understood, it is thought that the blue colour temperature in light affects melatonin suppression. The light of the LEDs chosen is a white light, approximating the colour of moonlight, without the blue light spectrum. This is also helpful to migrating salmon, who navigate by the blue light of stars and could be disorientated by the artificial lighting of the same colour.

White light is also believed to provide equivalent visual task lighting at a lower luminance than non-white light. In the application of outdoor lighting, white light, combined with low glare, is believed to lead to better pedestrian and driver safety.

The Directive on the restriction of certain hazardous substances in electrical and electronic equipment, commonly referred to as the Restriction of Hazardous Substances Directive (RoHS) was adopted by the European Union in February of 2003. This directive restricts the use of six hazardous substances in electrical equipment, including light bulbs. This directive has not been adopted in North America, however companies which meet the requirements under the directive can label their products as such. RUUD street lighting is labeled as RoHS compliant.

## 5. Conclusions

The LED streetlight Pilot in Dawson showed a potential energy savings of 266.2kWh/ light or 64% over the existing HPS lights. The cost of replacing HPS lights with LED lights is reasonable in a variety of scenarios, all of which have passed the standard DSM economic tests despite higher initial capital costs. The lights performed well in Yukon conditions, appearing to become more efficient during periods of extreme cold.

It is recommended to pursue LED streetlighting in the Yukon by proceeding with a follow-up pilot to choose the specific light to be used and developing the information needed to create a LED streetlight specific regulatory schedule. While the LED lights are suitable for residential setting, YEC should continue to keep apprised of efficient technologies that could compete with LEDs or be applicable to highway lighting.

## **APPENDICES**

### **Appendix A: RUUD Beta B LED Technical Information**



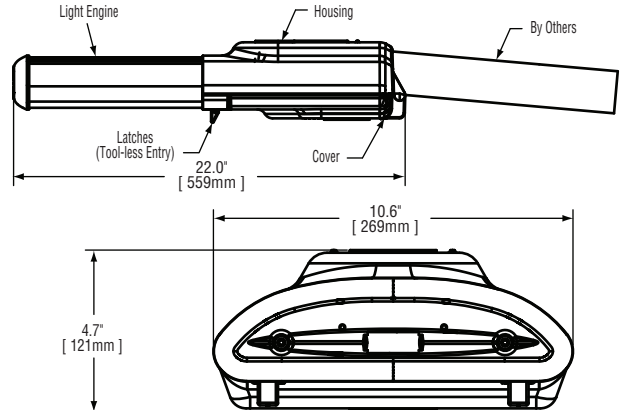

Notes:

Product	Family	Mounting	Optic	# of LEDs (x 10)	LED Series	Voltage	Color Options	Factory-Installed Options
X	SL Streetlight	O <sup>1</sup> Horizontal Tenon	3 <sup>2</sup> Type III	04	C	U Universal 120-277V	S Silver <sup>4</sup>	7 4300K Color Temperature <sup>5</sup>
			H <sup>3</sup> Type III w/ BLS	05			T Black <sup>4</sup>	CY 0-10V Dimming (525mA maximum) <sup>6,7</sup>
				06			Z Bronze <sup>4</sup>	D 700mA Drive Current <sup>8</sup>
							V Universal 347-480V	DY 0-10V Dimming (700mA maximum) <sup>6,7</sup>
							B Platinum	F Fuse <sup>9,10</sup>
							W White <sup>4</sup>	G Hi/Low (175/350/525, dual circuit input) <sup>11</sup>
								H 350mA Drive Current <sup>12</sup>
								J Door Safety Tether <sup>13</sup>
								M Power Door <sup>14,15</sup>
								N No Quick Disconnect Harness or Leveling Bubble <sup>16</sup>
								R NEMA Photocell Receptacle <sup>17</sup>

Click here for Utility option.

For additional options, see IP66 spec sheet.

Footnotes

- Horizontal tenon mount
- IESNA Type III Medium distribution
- IESNA Type III Medium distribution with backlight control
- Light engine portion of extrusion is not painted and will remain natural aluminum regardless of color selection
- Color temperature per fixture; minimum 70 CRI
- Control by others
- Refer to dimming spec sheet for availability and additional information
- Driver operates at 700mA instead of the standard 525mA providing a higher lumen output and a shorter life
- Not available with G option when V voltage is selected
- When code dictates fusing use time delay fuse
- Refer to multi level spec sheet for availability and additional information
- Driver operates at 350mA instead of the standard 525mA providing a lower lumen output and a longer life
- Stainless steel aircraft cable
- All connections between door and fixture are shipped unconnected from the factory; door release spring included to open door automatically when the latches are released
- Hinge retaining clips not included as part of this option
- Standard product features unless N option is specified; door clips not included
- Not available with G option

LED PERFORMANCE SPECS

# of LEDs	Initial Delivered Lumens – Type III Medium @ 6000K	B U G			Initial Delivered Lumens – Type III Medium w/ Backlight Control @ 6000K	B U G			Initial Delivered Lumens – Type III Medium @ 4300K	B U G			System Watts 120-277V	Total Current @ 120V	Total Current @ 230V	Total Current @ 277V	System Watts 347-480V	Total Current @ 347V	Total Current @ 480V	L <sub>70</sub> Hours** @ 25° C (77° F)				
		Rating***				Rating***				Rating***											Rating***			
<b>350mA Fixture Operating at 25° C (77° F)</b>																								
40	3,476 (04)	1	1	1	2,259 (04)	0	1	1	3,049 (04)	1	1	1	2,287 (04)	0	1	1	47	0.40	0.22	0.20	53	0.15	0.16	153,000
50	4,248 (05)	2	2	2	3,186 (05)	0	1	1	3,726 (05)	2	2	2	2,795 (05)	0	1	1	64	0.53	0.29	0.25	70	0.20	0.19	141,000
60	5,098 (06)	2	2	2	3,823 (06)	1	2	1	4,472 (06)	2	2	2	3,354 (06)	0	1	1	76	0.62	0.34	0.29	81	0.23	0.20	131,000
<b>525mA (Standard) Fixture Operating at 25° C (77° F)</b>																								
40	4,658 (04)	2	2	2	3,493 (04)	0	1	1	4,085 (04)	2	2	2	3,064 (04)	0	1	1	70	0.59	0.32	0.28	76	0.22	0.20	96,000
50	5,693 (05)	2	2	2	4,270 (05)	1	2	1	4,993 (05)	2	2	2	3,745 (05)	1	2	1	95	0.80	0.42	0.36	101	0.29	0.24	85,000
60	6,831 (06)	2	2	2	5,123 (06)	1	2	2	5,992 (06)	2	2	2	4,494 (06)	1	2	1	113	0.94	0.50	0.42	119	0.34	0.27	79,000
<b>700mA Fixture Operating at 25° C (77° F)</b>																								
40	5,700 (04)	2	2	2	4,275 (04)	1	2	1	5,000 (04)	2	2	2	3,750 (04)	1	2	1	98	0.83	0.44	0.37	104	0.30	0.24	65,000
50	6,967 (05)	2	2	2	5,225 (05)	1	2	2	6,111 (05)	2	2	2	4,583 (05)	1	2	1	124	1.04	0.55	0.46	131	0.38	0.30	56,000
60	8,361 (06)	3	2	3	6,270 (06)	1	3	2	7,333 (06)	2	2	2	5,500 (06)	1	2	2	146	1.23	0.64	0.54	154	0.44	0.34	50,000

\* Utilizes magnetic step-down transformer

\*\* For recommended lumen depreciation data see TD-13

\*\*\* For more information on the IES BUG (Backlight-Uplight-Glare) Rating visit [www.iesna.org/PDF/Erratas/TM-15-07BugRatingsAddendum.pdf](http://www.iesna.org/PDF/Erratas/TM-15-07BugRatingsAddendum.pdf)

**General Description**

Fixture housing is all aluminum construction. Standard fixture utilizes terminal block for power input suitable for #2-#14 AWG wire and operates at 525mA. Drive current is field switchable on 40, 50 and 60 LED units (50 & 60 LED units require two drivers). Fixture is designed to mount on 1.25" IP (1.675" O.D.) and/or 2" IP (2.375" O.D.) horizontal tenon and is adjustable +/- 5° to allow for fixture leveling (includes leveling bubble to aid in this process). Fixture carries a limited five year warranty.

**Electrical**

Modular design accommodates varied lighting output from high power, white, 6000K (+/- 500K per full fixture), minimum 70 CRI, long life LED sources. 120-277V 50/60 Hz, Class 1 LED drivers are standard. 347-480V 50/60 Hz option is available. LED drivers have power factor >90% and THD <20% at full load. Units provided with integral 9kV surge suppression protection standard. Quick disconnect harness suitable for mate and break under load provided on power feed to driver for ease of maintenance. Surge protection tested in accordance with IEEE C62.41.2 and ANSI standard 62.41.2.

**Finish**

Exclusive Colorfast DeltaGuard® finish features an E-Coat epoxy primer with an ultra-durable silver powder topcoat, providing excellent resistance to corrosion, ultraviolet degradation and abrasion. Bronze, black, white and platinum bronze powder topcoats are also available. The finish is covered by our 10 year limited warranty.

Fixture and finish are endurance tested to withstand 5,000 hours of elevated ambient salt fog conditions as defined in ASTM Standard B 117.

**Testing & Compliance**

UL listed in the U.S. and Canada for wet locations. Consult factory for CE Certified products. RoHS compliant. Meets CALTrans 611 Vibration Testing and GR-63-CORE Section 4.4.1/5.4.2 Earthquake Zone 4. International Dark-Sky Association approved.

**Patents**

U.S. and international patents granted and pending. BetaLED is a division of Ruud Lighting, Inc. For a listing of Ruud Lighting, Inc. patents, visit [www.uspto.gov](http://www.uspto.gov).

**Field-Installed Accessories**

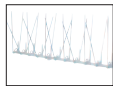

**Bird Spikes for Light Engine**  
XA-BRDSPK60

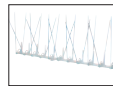

**Bird Spikes Kit for Housing**  
XA-BRDSPKHSG

**Photometrics**

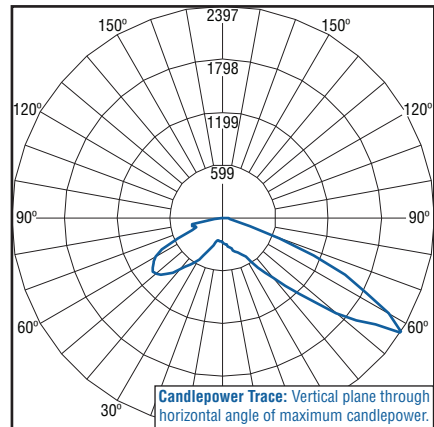

Independent Testing Laboratories certified test. Report No. ITL63266. Candlepower trace of 6000K, 40 LED Type III Medium streetlight luminaire with 4,696 initial delivered lumens operating at 525mA. **All published luminaire photometric testing performed to IESNA LM-79-08 standards.**

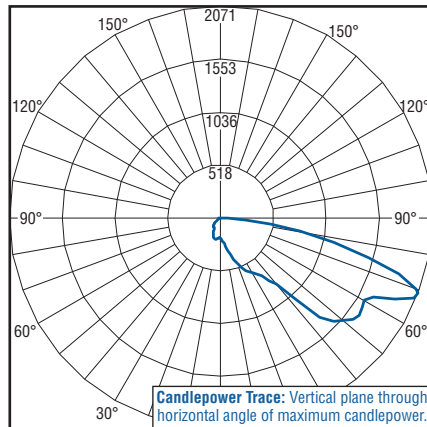

Independent Testing Laboratories certified test. Report No. ITL64192. Candlepower trace of 6000K, 40 LED Type III Medium streetlight luminaire with backlight control and 3,178 initial delivered lumens operating at 525mA. **All published luminaire photometric testing performed to IESNA LM-79-08 standards.**

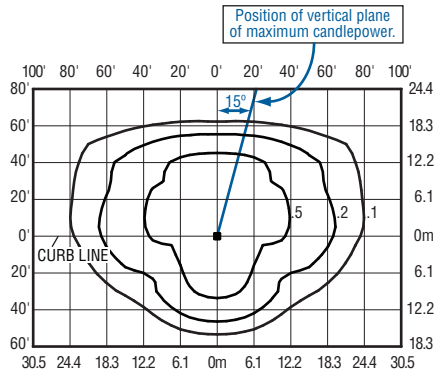

Isofootcandle plot of 6000K, 60 LED Type III Medium streetlight luminaire at 25° A.F.G. Luminaire with 6,831 initial delivered lumens operating at 525mA. Initial FC at grade.

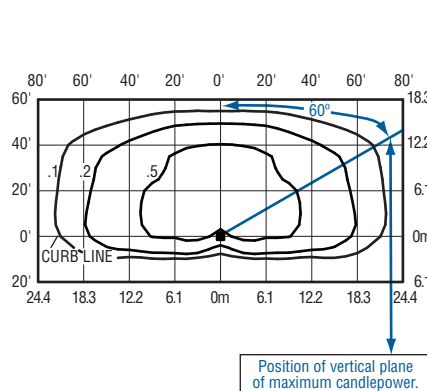

Isofootcandle plot of 6000K, 60 LED Type III Medium streetlight luminaire with backlight control at 25° A.F.G. Luminaire with 5,123 initial delivered lumens operating at 525mA. Initial FC at grade.

**LEDway® EPA & Weight Calculations**

	Approximate Weight 120-277V*	
40-60 LED fixture	16.0 lbs.	
EPA		
<b>Horizontal Tenon Mount</b>		
1 fixture	0.685	
EPA		
<b>Round External Mount / Square Internal Mount Horizontal Tenons with Fixture(s)</b>		
PT/PD-1H	Single	0.905
PT/PD-2H(90)	90° Twin	1.189
PT/PD-2H(180)	180° Twin	1.590
PT/PD-3H(90)	90° Triple	1.774
PT/PD-3H(120)	120° Triple	1.590
PT/PD-4H(90)	90° Quad	2.178

\*Add 5 lbs. for transformer in 347-480V fixtures



**Appendix B: Dawson Pilot LED Streetlight Layout**

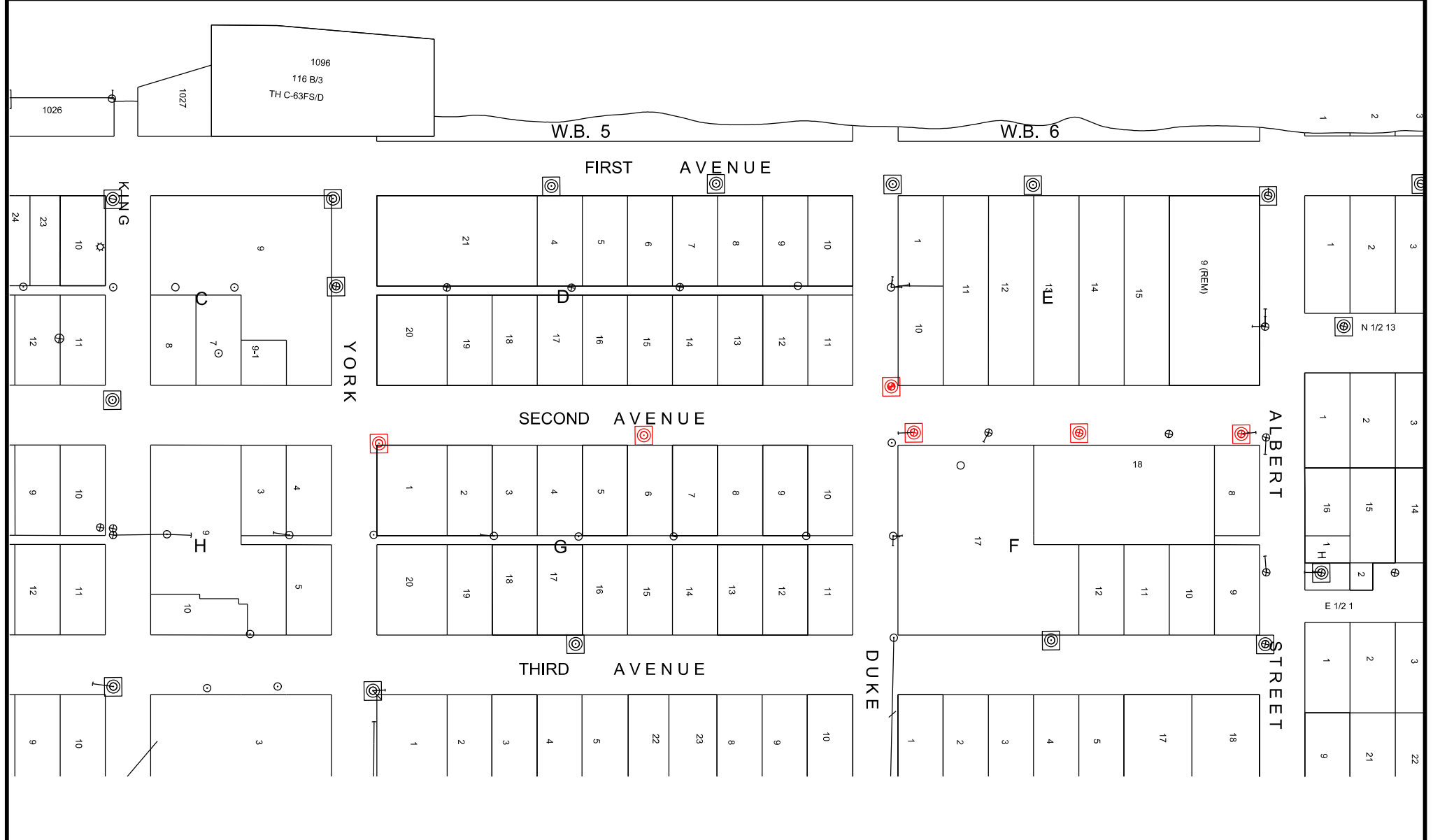

**YUKON ENERGY CORPORATION**

**DAWSON LED STREET LIGHT LOCATIONS**

**DATE:** AUG 2011

**DRWG. ■** DAWSON LED

**Appendix C: Public Survey Methodology, Questionnaire and Results**

## Survey Methodology

### Target Respondents:

All residents, businesses and organizations in Dawson City (or vicinity) who are customers of Yukon Energy. Includes residents across the river and out to Henderson Corner. (Response rate = # of responses /total # of Dawson City customers). Renters would not be captured in this survey (identified survey gap).

### Timing:

Pre mail out announcement in Dawson newspaper (Klondike Sun) and posted on City of Dawson website to be updated as a reminder notice mid February, 2011. A midterm survey will be mailed out before February 1, 2011. Responses are to be postmarked no later than February 28, 2011.

### Method:

Mail out was chosen because it requires less preparation time and less expertise in survey design. Mailed surveys provide anonymity to respondents and allow YEC to sample a larger, more comprehensive group of customers. This survey method requires fewer, less complex questions (without "skip patterns") but necessitates a longer data collection period.

### Incentives:

Incentives have proven to improve response rates to mail in surveys by at least 20%.

Pre: A pre-stamped return envelope will be provided with each survey.

Post: A separate sheet for people to write their name/ address/ phone number on will also be included for those who wish to be entered into a draw for 2 outdoor LED flood lights (Value approx. \$110.00)

### Response Mechanism:

Anonymous survey responses can be dropped off at YEC office in Dawson or mailed to YEC office in Whitehorse via prepaid envelope. Customer Service reps to encourage customers to participate in the survey when speaking to customers.

### Evaluation of responses:

Percentage responses to each question based on entire data set, and further divided by self- identified subset from question 1. Statistical assessment must not violate confidentiality of respondents.

### Communication of results:

Survey results to be communicated to customers via future mail out (could be part of final data analysis mail out). Results also posted on YEC web site and provided to ESC as per contribution agreement.

## Survey Questionnaire

YUKON  
ENERGY



*Your Needs Power What We Do.....*

As part of Yukon Energy's commitment to conduct research and develop a demand side management (DSM) program, we installed 6 LED streetlights on 2<sup>nd</sup> Avenue in Dawson City last fall. Preliminary information on their performance and energy consumption is in the accompanying newsletter. In addition to collecting technical data, it is important to us that we get feedback from residents and businesses about the lights. **Please take a few minutes to share your views with us by completing this survey and enter our draw to for a chance to win two outdoor LED flood lights (value \$110.00).**

**Completed surveys may be dropped off at our Yukon Energy office in Dawson or mailed in the envelope provided. Surveys must be returned to our Dawson office or postmarked by February 28, 2011.** Questions? Please call Janet Patterson at (867) 393-5333.

1. Are you responding as a resident or a business/organization?

Resident       Business/Organization

2. Have you seen the LED streetlights on 2<sup>nd</sup> Avenue in Dawson when they were turned on?

Yes       No

3. Do you like the new LED streetlights?

Yes       No       No Opinion

Because \_\_\_\_\_

\_\_\_\_\_

4. Do you think the LED streetlights provide the right amount of light in the area?

Yes       No, they are not bright enough       No, they are too bright

*Continued on the other side...*

5. Backlight shields were added to our test lights to reduce light pollution. Do you think the LED streetlights reduce light pollution?

Yes       No

Because \_\_\_\_\_  
\_\_\_\_\_

6. Do you like the colour of light that the LED streetlights produce?

Yes       No

Because \_\_\_\_\_  
\_\_\_\_\_

7. Would you support switching all streetlights to LED's in Dawson over the coming years? Why or why not?

Yes       No

Because \_\_\_\_\_  
\_\_\_\_\_

8. Do you have any other comments about the LED streetlight pilot project in Dawson City?

\_\_\_\_\_  
\_\_\_\_\_

Thank You. Your views are important to us. Results of this survey will be available on Yukon Energy's web site in March (<http://www.yukonenergy.ca>).



## Survey Results – Business and Residential

YUKON  
ENERGY



*Your Needs Power What We Do.....*

**1. Are you responding as a resident or a business/organization?**

Resident

9 Business/Organization

**2. Have you seen the LED streetlights on 2<sup>nd</sup> Avenue in Dawson when they were turned on?**

8 Yes

1 No

**3. Do you like the new LED streetlights?**

8 Yes

0 No

1 No Opinion

Because - Saves energy & money; saves energy and are bright; look a bit like moonlight; environmentally sound choice; inconvenient location

**4. Do you think the LED streetlights provide the right amount of light in the area?**

8 Yes

No, they are not bright enough

No, they are too bright

**5. Backlight shields were added to our test lights to reduce light pollution. Do you think the LED streetlights reduce light pollution?**

6 Yes

0 No

3 No response because didn't notice; no opinion; don't know

**6. Do you like the colour of light that the LED streetlights produce?**

8 Yes

0 No

Because - looks like moonlight; 1 NR & no opinion

*Continued on the other side...*

**7. Would you support switching all streetlights to LED's in Dawson over the coming years?  
Why or why not?**

9 Yes            0 No

Because- it would reduce our town's energy consumption; why years?; energy efficiency; they look nice; makes sense to save \$; energy saver; it would reduce "running costs" for the city and is more environmentally responsible

**8. Do you have any other comments about the LED streetlight pilot project in Dawson City?**

- it would reduce "running costs" for the city and is more environmentally responsible; hopefully we can redo the whole community with these lights; it's nice were on the list/ taking Dawson into consideration!!; would like to see is we could have the number of lights increased in some areas such as schools; lights could have been better located;



**1. Are you responding as a resident or a business/organization?**

67 Resident                      Business/Organization

**2. Have you seen the LED streetlights on 2<sup>nd</sup> Avenue in Dawson when they were turned on?**

65 Yes                      2 No

**3. Do you like the new LED streetlights?**

58 Yes                      4 No                      5 No Opinion

Yes because, supposed to reduce energy consumption; good light – less cost; better lighting; I can see better; brighter than the old ones also should put light in between avenues, its dark down north end; need more lights; bright, clear; disperses light better; can see the lights from 2 blocks away; nice, non-intrusive light; energy efficient; efficient illumination at lower cost; longer lasting bulbs; right amount of light; better light and less energy; ; seem brighter than old yellowish HPS lights (but not too bright); provide adequate light; illumination up to alleyways; these lighting makes the street seem lighter and easier to see; better coverage of the street; whiter light is more natural; brighter and not so yellow; more streetlights; a move in the right direction; brighter, not so dull and yellow looking; great light quality, can see further.

No because, too bright- maybe if it was not a “white light” yellow or amber would be more sufficient; in contrast to existing lights, LED’s give off a cold light and there is poor lighting between them (shadowy); ravens like the existing lights because they give off heat that is important to them on very cold nights

**4. Do you think the LED streetlights provide the right amount of light in the area?**

58 Yes                      5 No, they are not bright enough                      3 No, they are too bright

*Continued on the other side...*

**5. Backlight shields were added to our test lights to reduce light pollution. Do you think the LED streetlights reduce light pollution?**

44 Yes      5 No

Yes, because not a big glow; less light goes upward; I want to see the night sky especially the northern lights; light is nice and diffuse; I think so; what's light pollution?; light pollution has never been an issue before but good to know that Yukon is getting some protection from it; much cleaner, crisper light

No, because white light shines into the residents home, light is bright and covers more area; who determines if there is or isn't light pollution?

No response – 14 what's light pollution? ; don't know; worrying about lite reduction in the Yukon is redundant, we need all the lite we can get in winter; not a problem in dawson; probably; who cares they're better lights; not much difference; not much difference?

**6. Do you like the colour of light that the LED streetlights produce?**

56 Yes      8 No

Yes, because I like LED lights; never been fond of the yellow/orange; clearer than yellow; they are OK, back in the day the lights were a white light so...; things look brighter at night; seems brighter; lots of light to see people; its softer; more natural; close to white light but somehow more diffuse; improved visibility; more realistic; only for the areas outside the downtown historical area; greater range of vision and truer colours; they are white lights so they don't distort the surroundings like the traditional HPS yellow/orange light; nice and bright. Great white color.

No, because too white; cold and shadowy; too bright; should be little yellow; I would like to see the older style lights in the historical downtown core as they go with the building in the area; could look warmer.

No response (3) visibility is fine, colour not so important; neutral;

**7. Would you support switching all streetlights to LED's in Dawson over the coming years? Why or why not?**

59 Yes      5 No

Yes, because for the areas outside the downtown historical core only; safety and energy savings over time; much brighter which is good. Dawson is very dark in the winter; lower cost; if it lowers energy consumption over time, why not?; only if they truly are efficient and cost

*Continued on the other side...*

effective (longevity); easier to see at night; reduced power consumption; reduce pollution & expenses to spend \$ on other items such as water improvement; reduce energy costs and hopefully those savings can be passed on to the consumer; safety from dogs at night; good light for reduced power cost; less energy and brighter; saving \$; uses less power; strong support for any measures that reduce light pollution; reduce o&m costs; more lights and goes little further than before; they do the same job, if not a better one and most importantly they save energy; both energy savings and better quality light; cost savings and reduced light pollution; to save money; energy efficiency and longevity; they contain no mercury and few toxins than alternatives; energy savings; the brightness lets you feel safer because they are so bright and white.

No because, want older style lights in historic downtown core; we don't know enough yet; do more tests, cost analysis, cost attributed to rate payers?; they're not bright enough, perhaps you could switch every second light, that way there is adequate light and reduction of light pollution; I will be very unhappy if Yukon Energy puts out capital monies for something that doesn't need to be fixed. I don't want to support an outside company for fixed assets instead of reducing user fees or proper maintenance.

No response (3)

8. Do you have any other comments about the LED streetlight pilot project in Dawson City?

- The ravens may freeze without their heater perch; don't forget the ravens, they like the warmth of existing lights
- Change them all
- Great project!; good job; thumbs up!; great idea; about time, good work!; Yay!
- Would like to reduce energy consumption and light pollution in any ways possible
- Too modern
- Saves Dawson \$\$
- Quantum dot technology will likely replace LED's within 5 years. This is how fast this technology is advancing
- Please pass to your customers the savings by lowering your rates for electricity
- How long will the bulbs last?
- Will they be raven proof?
- If they reduce power and save \$ change them all
- Great lights, put up all over downtown
- Well done! Improvements in 2 directions 1) better light 2) reduced cost
- Need to do streetlight project slowly as not to infringe on Dawson taxpayers extremely

*Continued on the other side...*

- Use shields which would be more compatible with Dawson's historical character
- I would like to see a graph showing the energy saving in 5 years, including cost of lites, replacement, etc.
- Whatever is healthier for our environment, ourselves and more economical seems the best for a long term plan
- Good green initiative ☺
- Good update to Dawson's dark streets
- Overall I think it's a good idea to reduce energy consumption during the peak winter use period
- Sure they burn 70% less power, what do they cost? What's the cost recovery? Will they need replacing before that is realized?
- Try another street like 5<sup>th</sup> avenue for a year – it's a busier street than 2<sup>nd</sup>.
- I really don't know if LED produce more light or what
- Which Alberta company are we supporting now??
- Bogus!
- Please ensure energy savings are passed onto customers
- Thanks for having a trial and a survey
- All government buildings should use LED lights to reduce energy by 70%, especially Yukon Housing apartment complexes and parking lots.
- Hope to see more LED lights and I would encourage further innovation
- Great idea! Thank you!
- Great lights!

**Appendix D: Lumen Monitoring Datasheet and Results**

## Light Meter Readings Template

### LED Pilot Project – Dawson City – Light Meter Readings and General Observations

Fax to Krista (867) 393-5401

Date: \_\_\_\_\_

Time: \_\_\_\_\_

Recorded by: \_\_\_\_\_

Reason for Check:  Monthly

Ice Fog

Below -40C

#### Light Meter Readings

Light 1 (PP121) \_\_\_\_\_ directly below

\_\_\_\_\_ 5 meters in front

\_\_\_\_\_ 5 meters behind (if possible)

\_\_\_\_\_ 5 meters to the left (if pole is behind you)

\_\_\_\_\_ 5 meters to the right (if pole is behind you)

Light 2 (PP119) \_\_\_\_\_ directly below

\_\_\_\_\_ 5 meters in front

\_\_\_\_\_ 5 meters behind (if possible)

\_\_\_\_\_ 5 meters to the left (if pole is behind you)

\_\_\_\_\_ 5 meters to the right (if pole is behind you)

Light 3 (PP117) \_\_\_\_\_ directly below

\_\_\_\_\_ 5 meters in front

\_\_\_\_\_ 5 meters behind (if possible)

\_\_\_\_\_ 5 meters to the left (if pole is behind you)

\_\_\_\_\_ 5 meters to the right (if pole is behind you)



Light 4 (PP115) \_\_\_\_\_ directly below  
\_\_\_\_\_ 5 meters in front  
\_\_\_\_\_ 5 meters behind (if possible)  
\_\_\_\_\_ 5 meters to the left (if pole is behind you)  
\_\_\_\_\_ 5 meters to the right (if pole is behind you)

Light 5 (PP145A) \_\_\_\_\_ directly below  
\_\_\_\_\_ 5 meters in front  
\_\_\_\_\_ 5 meters behind (if possible)  
\_\_\_\_\_ 5 meters to the left (if pole is behind you)  
\_\_\_\_\_ 5 meters to the right (if pole is behind you)

Light 6 (PP148A) \_\_\_\_\_ directly below  
\_\_\_\_\_ 5 meters in front  
\_\_\_\_\_ 5 meters behind (if possible)  
\_\_\_\_\_ 5 meters to the left (if pole is behind you)  
\_\_\_\_\_ 5 meters to the right (if pole is behind you)

HPS (PP\_\_\_\_\_) \_\_\_\_\_ directly below  
\_\_\_\_\_ 5 meters in front  
\_\_\_\_\_ 5 meters behind (if possible)  
\_\_\_\_\_ 5 meters to the left (if pole is behind you)  
\_\_\_\_\_ 5 meters to the right (if pole is behind you)

Are there issues with snow loading / icing on the lamp head? \_\_\_ Yes \_\_\_ No

If yes, what is the issue and what needs to be done to fix it?

---

Are birds an issue? (Do we need bird spikes?)    \_\_\_\_\_Yes    \_\_\_\_\_No

Other General Observations (eg. is it snowing?):

---

---

## Light Meter Readings Data (LED vs. HPS)

### Light Meter Readings (LUX) - LED Pilot Project - Dawson City

Light	Date	directly below	5 m. in front	5 m. behind	5 m. to left	5 m. to right	Weather
1 (PP121)	Jan 19/11	9.3	11.1	1.2	10.2	9.9	-45
	Jan 10/11	9.1	10.8	0.9	10.8	10.2	unknown (some ice fog)
	Jan 5/11	8.2	10.4	1.7	11.3	9.6	unknown (clear)
	Dec 29/10	10	10.1	1.4	9.3	11.5	-17
	Dec 20/10	9.8	10.1	1.2	9.4	9.5	-39
	Dec 13/10	9.2	10.8	1.6	13.5	11.3	snowing and - 30
	Dec 7/10	9.1	11.5	2.1	13.4	11.2	light snow and -15
	Dec 1/10	8.8	9.2	0.3	10	10	-37
	Nov 1/10	7.7	8.3	0.5	7.1	8.8	-13
mid term average		9.022	10.256	1.211	10.556	10.222	
2 (PP119)	Jan 19/11	8.7	11.7	1.6	11.2	7.4	-45
	Jan 10/11	9.5	12.3	1.5	10.4	10.9	unknown (some ice fog)
	Jan 5/11	7.5	9.6	1.1	9.2	9.1	unknown (clear)
	Dec 29/10	9.2	10.7	1.8	11	10.4	-17
	Dec 20/10	10.5	11.3	1.3	11.9	10.3	-39
	Dec 13/10	9.3	11.7	1.1	12.4	11.1	snowing and - 30
	Dec 7/10	8.7	10.7	2.3	12.1	10.2	light snow and -15
	Dec 1/10	8.8	9.7	0.6	8.5	8.3	-37
	Nov 1/10	7.5	9.6	1.1	9.2	9.1	-13
mid term average		8.856	10.811	1.378	10.656	9.644	

**Appendix E: Public Advertising and Newsletters**

### how can I get involved?

We want to know what you think of these lights by participating in a survey that will be mailed to all Dawson City customers in February. We also welcome your comments on our public blog or by email (see addresses below). Results of the pilot project will be sent to Dawson residents and will be posted on our website and blog in the late spring/early summer of 2011.

### want to know more?

1-866-926-3749 or 867-393-5333  
communications@yukonenergy.ca  
yukonenergy.ca | blog.yukonenergy.ca

In partnership with  energy solutions centre

# how's our lighting?



your needs power what we do



It's Yukon Energy's job to provide Yukoners with enough clean, affordable and reliable electricity to keep the lights on and businesses thriving. We are looking at all possible sources of clean energy so we don't have to burn any more diesel than necessary. We also know that the energy we have is precious. That's why we are developing an energy conservation (demand side management) program. An LED pilot project in Dawson City will be one part of the program.

### what's an LED?

LED stands for Light Emitting Diode, a kind of light source that's different from a traditional light bulb. When used in streetlights, they require at least 50 percent less energy than regular streetlights and have a longer life span. They are starting to be used in many cities around the world including places in Alaska and British Columbia.

### pilot project details

Yukon Energy will install six LED streetlights in Dawson City this month. They will be going up on Second Avenue between Albert and York streets (behind the City of Dawson offices & Firefighters' Museum).

During this pilot project, which will run from October to May 2011, we will monitor the lights for cold weather performance and energy use. We're asking people in Dawson to give us their opinions on these lights. If they work out well, we will look at replacing all our streetlights in Dawson, Faro and Mayo.

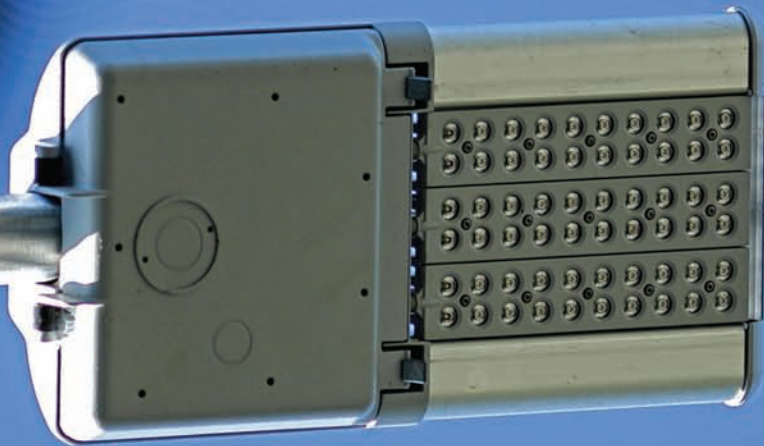

The LED lights will fit on the existing streetlight poles but will have a flatter shape than the High Pressure Sodium lights we are now using.



The LED lights are compliant with Dark Sky standards, and will be installed with back light shields to reduce light pollution. This photo shows the reduction in light pollution from the LED lights compared to the standard HPS lights.



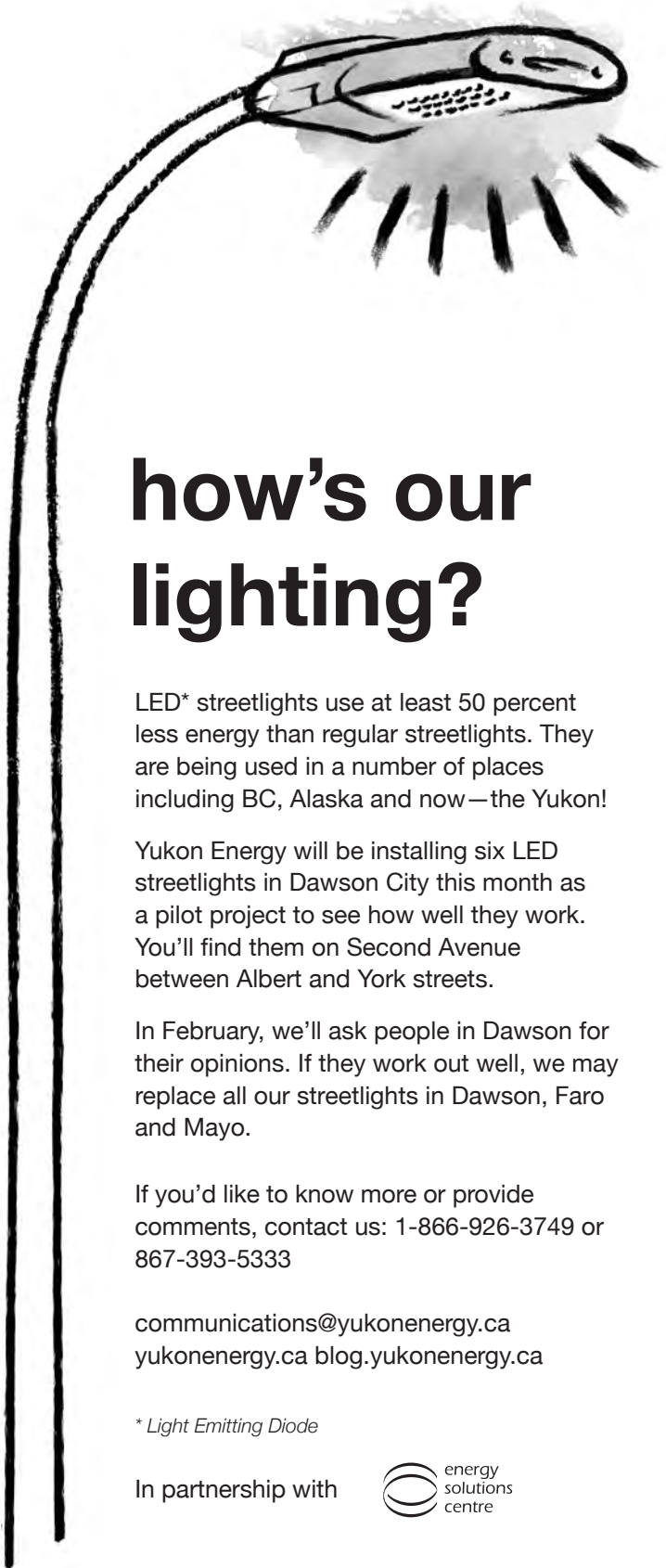

# how's our lighting?

LED\* streetlights use at least 50 percent less energy than regular streetlights. They are being used in a number of places including BC, Alaska and now—the Yukon!

Yukon Energy will be installing six LED streetlights in Dawson City this month as a pilot project to see how well they work. You'll find them on Second Avenue between Albert and York streets.

In February, we'll ask people in Dawson for their opinions. If they work out well, we may replace all our streetlights in Dawson, Faro and Mayo.

If you'd like to know more or provide comments, contact us: 1-866-926-3749 or 867-393-5333

[communications@yukonenergy.ca](mailto:communications@yukonenergy.ca)  
[yukonenergy.ca](http://yukonenergy.ca) [blog.yukonenergy.ca](http://blog.yukonenergy.ca)

\* *Light Emitting Diode*

In partnership with



**your needs power what we do**



# How's Our Lighting, Dawson?

## Update on LED Streetlight Pilot Project



Feb. 2011



### The Details

Last fall, Yukon Energy installed six LED streetlights in Dawson City. We wanted to find out how they would perform in extreme winter conditions compared to the traditional street lights. Now we're looking for your feedback. If you haven't seen the lights yet, check them out on Second Avenue between Albert and York Streets. Then fill out the accompanying survey and return it to Yukon Energy by Feb. 28, 2011. If you do, you'll have a chance to win two LED flood lights.



Dawson LEDs at  $-45^{\circ}\text{C}$ .

### Early Results

Over the last couple of months we've taken light meter readings in different weather conditions and have compared energy consumption information collected from dataloggers installed on each type of light. Here is what we've learned so far:

- Light meter readings have shown a consistent level of light for each of the LED streetlights. The level meets international standards for roadway lighting.
- The LED streetlights are using 70 percent less energy (on average) than the traditional HPS streetlight.
- There have not been any icing or weather related problems with LED streetlight performance.
- Public reaction to the LED lights has been largely positive.
- Our results, although preliminary, are consistent with the results from LED pilot projects in other parts of Canada and the U.S.

### What Happens Next?

Yukon Energy will continue to monitor the performance of the LEDs for the rest of the winter. We'll prepare a final report on the pilot project this summer and we will share the results with you.

### Want to Know More?

1-866-926-3749 or 867-393-5333  
[communications@yukonenergy.ca](mailto:communications@yukonenergy.ca)  
[www.yukonenergy.ca](http://www.yukonenergy.ca)  
[blog.yukonenergy.ca](http://blog.yukonenergy.ca)



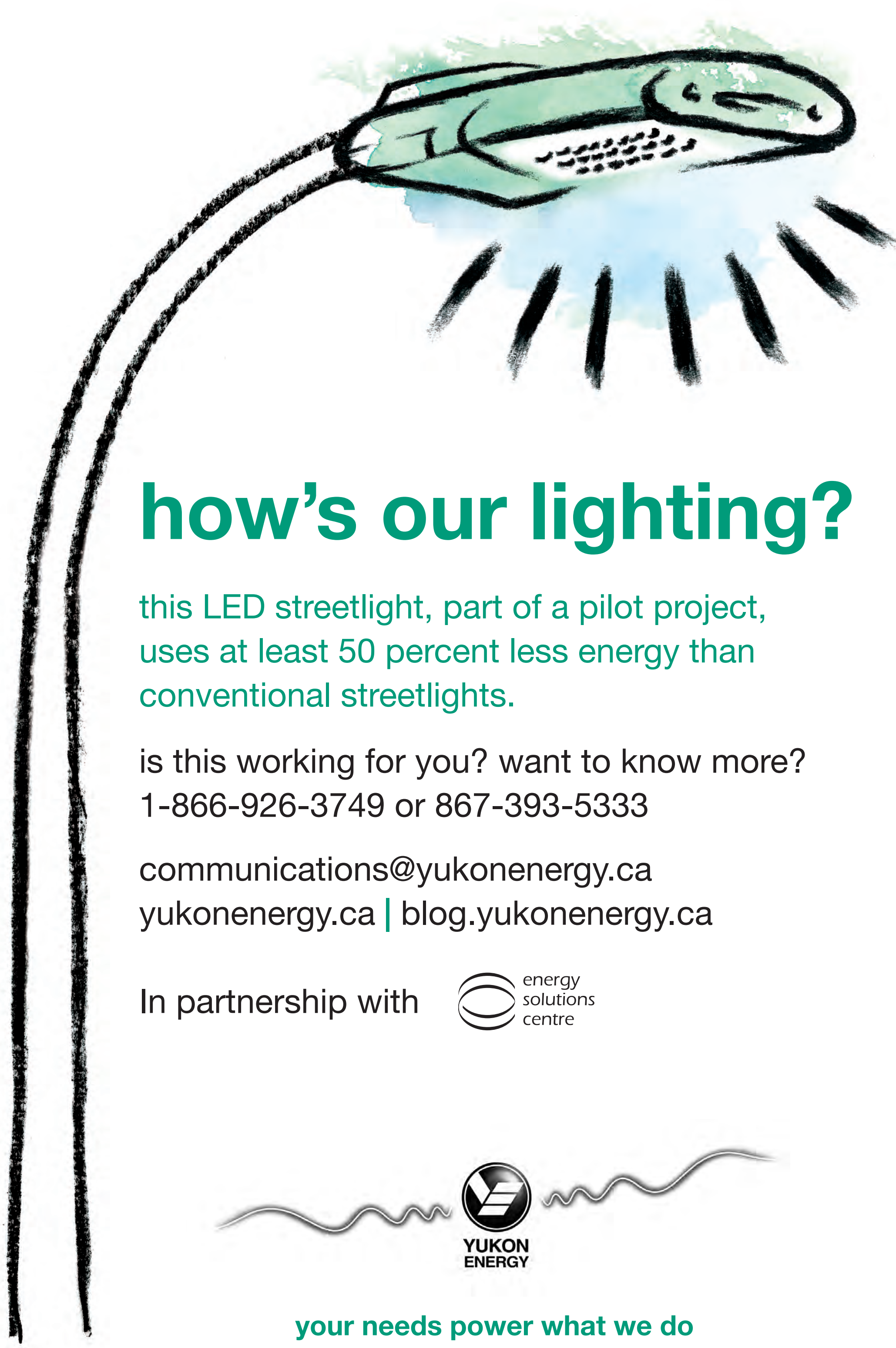

# how's our lighting?

this LED streetlight, part of a pilot project, uses at least 50 percent less energy than conventional streetlights.

is this working for you? want to know more?  
1-866-926-3749 or 867-393-5333

[communications@yukonenergy.ca](mailto:communications@yukonenergy.ca)  
[yukonenergy.ca](http://yukonenergy.ca) | [blog.yukonenergy.ca](http://blog.yukonenergy.ca)

In partnership with



**your needs power what we do**